



University of Bahrain
**Journal of the Association of Arab Universities for
Basic and Applied Sciences**

www.elsevier.com/locate/jaabas
www.sciencedirect.com



تدفق بويسويل الثابت وانتقال الحرارة لاجهاد السوائل الثنائي بين لوحين متوازيين مائلين عند اختلاف اللزوجة

م. فارووق¹، م.ت. رحيم¹، س.اسلام²، أ.م. صديقي³

¹ قسم الرياضيات، الجامعة الوطنية للكمبيوتر والعلوم الظاهرة، بيشاور، باكستان

² قسم الرياضيات، جامعة عبد الوالي خان، ماردان، باكستان

³ قسم الرياضيات، جامعة ولاية بنسلفانيا، يورك، بنسلفانيا، الولايات المتحدة الأمريكية

المخلص:

إن هدف هذا البحث هو دراسة تدفق بويسويل الغير متزن حراريا بين لوحين متوازيين مائلين تم تسخينهما بواسطة إجهاد السوائل الثنائي الغير إنضغاطي. نموذج رينولد استخدم لإعتماد اللزوجة على الحرارة. في هذه الدراسة لقد تم تطوير المعادلات التفاضلية الثنائية العادية الغير خطية العالية من معادلات الزخم والطاقة. لقد استخدمت طريقة الإضطراب للحصول على علاقات تحليلية تقريبية لتوزيعات اللزوجة والحرارة. لقد تم الحصول على علاقات مجال السرعة وتوزيع الحرارة وديناميكا الضغط ومعدل تدفق الحجم ومتوسط السرعة وإجهاد القص على اللوحين. إن تأثير العديد من المعاملات التي ظهرت على مسألة التدفق قد تمت مناقشتها وعرضها بأشكال بيانية.



University of Bahrain
**Journal of the Association of Arab Universities for
Basic and Applied Sciences**

www.elsevier.com/locate/jaaubas
www.sciencedirect.com



ORIGINAL ARTICLE

Steady Poiseuille flow and heat transfer of couple stress fluids between two parallel inclined plates with variable viscosity

M. Farooq ^{a,*}, M.T. Rahim ^a, S. Islam ^b, A.M. Siddiqui ^c

^a Department of Mathematics, National University of Computer & Emerging Sciences, Peshawar, Pakistan

^b Department of Mathematics, Abdul Wali Khan University, Mardan, Khyber Pakhtunkhwa, Pakistan

^c Department of Mathematics, Pennsylvania State University, York Campus, 1031 Edgecomb Avenue, York, PA 17403, USA

Received 3 October 2012; revised 15 December 2012; accepted 24 January 2013

Available online 1 April 2013

KEYWORDS

Couple stress fluid;
Reynold's model;
Brinkman number;
Perturbation technique;
Heat transfer

Abstract The purpose of this paper is to study the non-isothermal Poiseuille flow between two heated parallel inclined plates using incompressible couple stress fluids. Reynold's model is used for temperature dependent viscosity. We have developed highly non-linear coupled ordinary differential equations from momentum and energy equations. The Perturbation technique is used to obtain the approximate analytical expressions for velocity and temperature distributions. Expressions for velocity field, temperature distribution, dynamic pressure, volume flow rate, average velocity and shear stress on the plates are obtained. The influence of various emerging parameters on the flow problem is discussed and presented graphically.

© 2013 University of Bahrain. Production and hosting by Elsevier B.V. All rights reserved.

1. Introduction

In recent years, scientists have shown their interest in non-Newtonian fluids because of their applications in many natural, industrial and technological problems. Several authors cited a wide range of applications of non-Newtonian fluids that cover the flow of polymer solutions, food stuffs, drilling oil and gas wells, synthetic fibers and the extrusion of molten plastics. Tan and Xu (2002), Tan and Masuoka (2005a,b), Farooq et al. (2011, 2012), Shah et al. (2011), Chen et al. (2004) and Fetecau

and Fetecau (2002, 2003, 2005) have discussed some of the interesting fluid flow problems involving non-Newtonian fluids.

In order to explain the behavior of non-Newtonian fluids, different constitutive equations have been suggested. Among these, the couple stress fluid model introduced by Stokes (1966) has distinct characteristics, such as the presence of couple stresses, non-symmetric stress tensor and body couples. The couple stress fluid theory presented by Stokes suggests models for those fluids whose microstructure is mechanically momentous. The effect of microstructure on a liquid can be felt, if the characteristic geometric dimension of the problem considered is of the same order of magnitude as the size of the microstructure (Srinivasacharya and Kaladhar, 2011). To introduce a size dependent effect is one of the main features of couple stresses. The subject of classical continuum mechanics ignores the effect of size of material particles within the continua. This is unswerving with neglecting the rotational interaction among the particles of the fluid, which results in a symmetry of the force–stress tensor. However, this

* Corresponding author. Tel.: +92 3339007047; fax: +92 915822320.

E-mail address: farooq_nihal@hotmail.com (M. Farooq).

Peer review under responsibility of University of Bahrain.



Production and hosting by Elsevier

Nomenclature

\mathbf{V}	velocity vector	B_r	Brinkman number
U	reference velocity	M	viscosity index
H	height of plate	m	constant number
\mathbf{f}	body force	n	viscosity parameter
\mathbf{T}	Cauchy stress tensor		
\mathbf{I}	unit tensor		
\mathbf{A}_1	first Rivlin-Ericksen tensor	<i>Greek symbols</i>	
\mathbf{L}	gradient of \mathbf{V}	ϵ	small parameter
c_p	specific heat	η	couple stress parameter
p	non-dimensional dynamic pressure	Θ	dimensional temperature
p^*	dimensional dynamic pressure	Θ^*	non-dimensional temperature
u	dimensional velocity in the x -direction	Θ_0	lower plate temperature
u^*	non-dimensional velocity in the x -direction	Θ_1	upper plate temperature
x	dimensional x -coordinate	κ	thermal conductivity
x^*	non-dimensional x -coordinate	μ	dimensional coefficient of viscosity
y	dimensional y -coordinate	μ^*	non-dimensional coefficient of viscosity
y^*	non-dimensional y -coordinate	μ_0	reference viscosity
B	non-dimensional parameter	ρ	constant density of the fluid
		τ	extra stress tensor

cannot be true and a size dependent couple-stress theory is needed in some important cases for instance fluid flow with suspended particles. The spin field due to microrotation of these freely suspended particles set up an antisymmetric stress, which is known as couple-stress, and thus forming couple-stress fluid. The couple stress fluids are proficient of describing different types of lubricants, suspension fluids, blood etc. These fluids have applications in various processes that take place in the industry such as solidification of liquid crystals, extrusion of polymer fluids, colloidal solutions and cooling of metallic plate in a bath etc. Stokes has also written a review of couple stress fluid dynamics (Stokes, 1984) which contains an extensive study about these fluids. Basic ideas and techniques for both steady and unsteady flow problems of Newtonian and non-Newtonian fluids are given by Ellahi (Ellahi, 2009). The basic equations governing the flow of couple stress fluids are non-linear in nature and even of higher order than the Navier Stokes equations. Thus an exact solution of these equations is not easy to find. Different perturbation techniques are commonly used for obtaining approximate solutions of these equations.

Heat transfer flow has importance in different engineering applications such as the design of thrust bearings and radial diffusers' transpiration cooling, drag reduction and thermal recovery of oil. Heat transfer plays an important role in processing and handling of non-Newtonian mixtures (Tsai et al., 1988). The mechanics of nonlinear fluid flows is a challenge to mathematicians, engineers and scientists since the nonlinearity can manifest itself in different ways as is the case in the analysis of reactive variable viscosity flows in a slit with wall injection or suction. In our case, one of the reasons of the nonlinearity of the coupled ordinary differential equations is the temperature dependent viscosity. Flows with temperature dependent viscosity are studied by various researchers. (Yurusoy and Pakdemirli, 2002; Makinde, 2006, 2009, 2010).

In this paper, we study the heat transfer flow of incompressible couple stress fluids with temperature dependent viscosity between two parallel inclined plates kept at different temperatures. The basic governing equations for couple stress fluids are given in Section 2. In Section 3, the Poiseuille flow is

formulated and perturbation solutions are obtained for velocity field and temperature distribution. In Section 4, we compute volume flux, average velocity and shear stress on the plates. Section 5 is devoted to results and discussion and conclusion is provided in Section 6.

2. Basic equations

The basic equations governing the flow of an incompressible couple stress fluid are (Siddiqui et al., 2006, 2008; Islam and Zhou, 2007, 2009; El-Dabe and El-Mohandis, 1995; El-Dabe et al., 2003)

$$\text{div} \mathbf{V} = 0, \quad (1)$$

$$\rho \frac{D\mathbf{V}}{Dt} = \text{div} \mathbf{T} - \eta \nabla^4 \mathbf{V} + \rho \mathbf{f}, \quad (2)$$

$$\rho c_p \frac{D\Theta}{Dt} = \kappa \nabla^2 \Theta + \mathbf{T} \cdot \mathbf{L}, \quad (3)$$

where \mathbf{V} is the velocity vector, ρ is the constant density, f is the body force per unit mass, \mathbf{T} is the Cauchy stress tensor, Θ is the temperature, κ is the thermal conductivity, c_p is the specific heat, \mathbf{L} is the gradient of \mathbf{V} , η is the couple stress parameter and the operator $\frac{D}{Dt}$ denotes the material derivative which is defined as:

$$\frac{D}{Dt} (*) = \left(\frac{\partial}{\partial t} + \mathbf{V} \cdot \nabla \right) (*).$$

The Cauchy stress tensor \mathbf{T} can be defined as:

$$\mathbf{T} = -p \mathbf{I} + \tau, \quad \tau = \mu \mathbf{A}_1, \quad (4)$$

where p is the dynamic pressure, \mathbf{I} is the unit tensor, μ is the coefficient of viscosity and \mathbf{A}_1 is the first Rivlin-Ericksen tensor defined as:

$$\mathbf{A}_1 = \mathbf{L} + \mathbf{L}^T, \quad \mathbf{L}^T \text{ is the transpose of } \mathbf{L}.$$

3. Formulation and solution of plane Poiseuille flow

Consider the steady flow of couple fluid between two infinite parallel inclined plates which are placed at $y = -H$ (lower

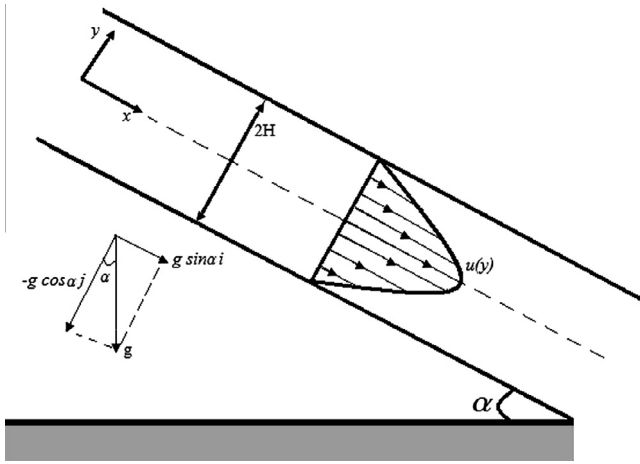

Figure 1 Geometry of the problem.

plate) and $y = H$ (upper plate). Plates are at rest and motion of the fluid is maintained due to both constant pressure gradient and gravity. The temperatures of lower and upper plates are kept at Θ_0 and Θ_1 respectively. The chosen coordinate system is shown in Fig. 1. The angle made by the plates and the horizontal direction is α . Viscosity of the fluid μ , is assumed to be a function of Θ . Velocity and temperature fields are of the form:

$$\mathbf{V} = \mathbf{V}(u, 0, 0), \quad u = u(y), \quad \text{and} \quad \Theta = \Theta(y). \quad (5)$$

Using these assumptions, we observe that the continuity Eq. (1) is identically satisfied and the momentum Eq. (2) reduces to

$$0 = -\frac{\partial p}{\partial x} + \frac{\partial}{\partial y}(\tau_{xy}) - \eta \frac{d^4 u}{dy^4} + \rho g \sin \alpha, \quad (6)$$

$$0 = -\frac{\partial p}{\partial y} - \rho g \cos \alpha, \quad (7)$$

$$0 = -\frac{\partial p}{\partial z}. \quad (8)$$

The pressure p , is obtained from Eq. (7) as

$$p = \rho g[x \sin \alpha - y \cos \alpha] + C, \quad (9)$$

where C is a constant of integration and can be calculated by applying the appropriate boundary condition. Eq. (8) implies that $p \neq p(z)$. Using Eq. (5) in Eq. (4), the non-zero components of the extra stress tensor τ are

$$\tau_{xy} = \mu \frac{du}{dy} = \tau_{yx}. \quad (10)$$

Substituting Eq. (10) into Eq. (6) we obtain

$$\eta \frac{d^4 u}{dy^4} - \mu \frac{d^2 u}{dy^2} - \frac{d\mu}{dy} \frac{du}{dy} + \frac{\partial p}{\partial x} - \rho g \sin \alpha = 0. \quad (11)$$

Eqs. (4), (5) and (10) transforms the energy Eq. (3) to the form

$$\frac{d^2 \Theta}{dy^2} + \frac{\mu}{\kappa} \left(\frac{du}{dy} \right)^2 + \frac{\eta}{\kappa} \left(\frac{d^2 u}{dy^2} \right)^2 = 0. \quad (12)$$

The associated boundary conditions are

$$u(-H) = u(H) = 0, \quad (13)$$

$$u''(-H) = u''(H) = 0, \quad (14)$$

$$\Theta(-H) = \Theta_0, \quad \Theta(H) = \Theta_1. \quad (15)$$

Eq. (13) is the usual no-slip boundary conditions. Eq. (14) implies that couple stresses are zero at the plates. We introduce the following non-dimensional parameters:

$$u^* = \frac{u}{U}, \quad y^* = \frac{y}{H}, \quad x^* = \frac{x}{H}, \quad \Theta^* = \frac{\Theta - \Theta_0}{\Theta_1 - \Theta_0}, \quad \mu^* = \frac{\mu}{\mu_0}, \quad p^* = \frac{p}{\mu_0 U / H},$$

$$B_r = \frac{\mu_0 U^2}{\kappa(\Theta_1 - \Theta_0)}, \quad B^2 = \frac{\mu_0 H^2}{\eta}, \quad G = -\frac{B^2 H^5}{\mu_0 U} \frac{\partial p}{\partial x} + \frac{\rho g H^4}{\eta U} \sin \alpha,$$

where U is the reference velocity, μ_0 is the reference viscosity and B_r is the Brinkman number. Using these dimensionless parameters, Eqs. (11) and (12) take the form (dropping asterisks)

$$\frac{d^4 u}{dy^4} - B^2 \mu \frac{d^2 u}{dy^2} - B^2 \frac{d\mu}{dy} \frac{du}{dy} - G = 0, \quad (16)$$

$$\frac{d^2 \Theta}{dy^2} + B_r \mu \left(\frac{du}{dy} \right)^2 + \frac{B_r}{B^2} \left(\frac{d^2 u}{dy^2} \right)^2 = 0, \quad (17)$$

and the corresponding boundary conditions (13)–(15) become

$$u(-1) = 0, \quad u(1) = 0, \quad (18)$$

$$u''(-1) = 0, \quad u''(1) = 0, \quad (19)$$

$$\Theta(-1) = 0, \quad \Theta(1) = 1. \quad (20)$$

Assume that the temperature dependent fluid viscosity μ is given by Reynold's model (Aksoy and Pakdemirli, 2010; Farooq et al., 2011, 2012; Massoudi and Christie, 1995; Chinyoka and Makinde, 2011; Reynolds, 1886; Szeri and Rajagopal, 1985). The dimensionless form of this model is

$$\mu = \exp(-M\Theta), \quad (21)$$

where $M = n(\Theta_1 - \Theta_0)$. Let $M = \epsilon m$, where ϵ is a small perturbation parameter. Using the Taylor series expansion, Eq. (21) reduces to

$$\mu \cong 1 - \epsilon m \Theta, \quad \frac{d\mu}{dy} \cong -\epsilon m \frac{d\Theta}{dy}. \quad (22)$$

Substituting Eq. (22) in the governing Eqs. (16) and (17), the following coupled system is obtained:

$$\frac{d^4 u}{dy^4} - B^2(1 - \epsilon m \Theta) \frac{d^2 u}{dy^2} + B^2 \epsilon m \frac{d\Theta}{dy} \frac{du}{dy} - G = 0, \quad (23)$$

$$\frac{d^2 \Theta}{dy^2} + B_r(1 - \epsilon m \Theta) \left(\frac{du}{dy} \right)^2 + \frac{B_r}{B^2} \left(\frac{d^2 u}{dy^2} \right)^2 = 0. \quad (24)$$

In order to solve these coupled ordinary differential equations with associated boundary conditions (18)–(20), we use the perturbation technique. Taking the approximate velocity and temperature profiles as

$$u = \sum_{i=0}^{\infty} \epsilon^i u_i \quad \text{and} \quad \Theta = \sum_{i=0}^{\infty} \epsilon^i \Theta_i. \quad (25)$$

Inserting Eq. (25) into Eqs. (23), (24), (18), (19) and (20) and then separating at each order of approximation, we obtain the following systems of equations along with the corresponding boundary conditions.

Zeroth order equations:

$$\frac{d^4 u_0}{dy^4} - B^2 \frac{d^2 u_0}{dy^2} - G = 0, \quad (26)$$

$$\frac{d^2 \Theta_0}{dy^2} + B_r \left(\frac{du_0}{dy} \right) + \frac{B_r}{B^2} \left(\frac{d^2 u_0}{dy^2} \right)^2 = 0, \quad (27)$$

$$u_0 = 0, \quad \frac{d^2 u_0}{dy^2} = 0, \quad \Theta_0 = 0, \quad \text{at } y = -1 \quad (28)$$

$$u_0 = 0, \quad \frac{d^2 u_0}{dy^2} = 0, \quad \Theta_0 = 1 \quad \text{at } y = 1. \quad (29)$$

1st order equations:

$$\frac{d^4 u_1}{dy^4} - B^2 \frac{d^2 u_1}{dy^2} + B^2 m \Theta_0 \frac{d^2 u_0}{dy^2} + B^2 m \left(\frac{du_0}{dy} \right) \left(\frac{d\Theta_0}{dy} \right) = 0, \quad (30)$$

$$\frac{d^2 \Theta_1}{dy^2} + 2B_r \left(\frac{du_1}{dy} \right) \left(\frac{du_0}{dy} \right) - B_r m \Theta_0 \left(\frac{du_0}{dy} \right)^2 + \frac{2B_r}{B^2} \left(\frac{d^2 u_0}{dy^2} \right) \left(\frac{d^2 u_1}{dy^2} \right) = 0, \quad (31)$$

$$u_1 = 0, \quad \frac{d^2 u_1}{dy^2} = 0, \quad \Theta_1 = 0, \quad \text{at } y = -1 \quad (32)$$

$$u_1 = 0, \quad \frac{d^2 u_1}{dy^2} = 0, \quad \Theta_1 = 0 \quad \text{at } y = 1. \quad (33)$$

The second order equations have not been considered because of lengthy calculations. Solving Eqs. (26) and (27) with the corresponding boundary conditions (28) and (29) we have

$$u_0(y) = \Gamma_0 - \Gamma_1 y^2 + \Gamma_2 \cosh[By], \quad (34)$$

$$\Theta_0(y) = \Upsilon_0 - \Upsilon_1 y^2 - \Upsilon_2 y^4 - \Upsilon_3 \cosh[By] - \Upsilon_4 \cosh[2By] + \Upsilon_5 y \sinh[By]. \quad (35)$$

Substituting Eqs. (34) and (35) into Eqs. (30) and (31) and then solving with respect to the boundary conditions (32) and (33), we obtain

$$\begin{aligned} u_1(y) = & (\Gamma_3 - \Gamma_4 \cosh[By] + \Gamma_5 \cosh[2By] + \Gamma_6 \cosh[3By])y^0 \\ & + (\Gamma_7 \sinh[By] - \Gamma_8 \sinh[2By])y \\ & + (\Gamma_9 - \Gamma_{10} \cosh[By])y^2 + (\Gamma_{11} \sinh[By])y^3 \\ & + (\Gamma_{12} - \Gamma_{13} \cosh[By])y^4 + (\Gamma_{14} \sinh[By])y^5 \\ & + \Gamma_{15}y^6, \end{aligned} \quad (36)$$

$$\begin{aligned} \Theta_1(y) = & (\Upsilon_6 + \Upsilon_7 \cosh[By] + \Upsilon_8 \cosh[2By] - \Upsilon_9 \cosh[3By] - \Upsilon_{10} \cosh[4By])y^0 \\ & + (-\Upsilon_{11} \sinh[By] + \Upsilon_{12} \sinh[2By] + \Upsilon_{13} \sinh[3By])y \\ & + (-\Upsilon_{14} + \Upsilon_{15} \cosh[By] - \Upsilon_{16} \cosh[2By])y^2 \\ & + (-\Upsilon_{17} \sinh[By] + \Upsilon_{18} \sinh[2By])y^3 \\ & + (\Upsilon_{19} + \Upsilon_{20} \cosh[By] - \Upsilon_{21} \cosh[2By])y^4 \\ & - (\Upsilon_{22} \sinh[By] + \Upsilon_{23} \sinh[2By])y^5 + (\Upsilon_{24} + \Upsilon_{25} \cosh[By])y^6 \\ & - \Upsilon_{26}y^8. \end{aligned} \quad (37)$$

Inserting Eqs. (34)–(37) into Eq. (25), the perturbation solutions upto order one are:

$$\begin{aligned} u(y) = & \Gamma_0 - y^2 \Gamma_1 + \cosh[By] \Gamma_2 \\ & + \epsilon \{ (\Gamma_3 - \Gamma_4 \cosh[By] + \Gamma_5 \cosh[2By] + \Gamma_6 \cosh[3By])y^0 \\ & + (\Gamma_7 \sinh[By] - \Gamma_8 \sinh[2By])y + (\Gamma_9 - \Gamma_{10} \cosh[By])y^2 \\ & + (\Gamma_{11} \sinh[By])y^3 + (\Gamma_{12} - \Gamma_{13} \cosh[By])y^4 \\ & + (\Gamma_{14} \sinh[By])y^5 + \Gamma_{15}y^6 \}, \end{aligned} \quad (38)$$

$$\begin{aligned} \Theta(y) = & \Upsilon_0 - y^2 \Upsilon_1 - y^4 \Upsilon_2 - \cosh[By] \Upsilon_3 - \cosh[2By] \Upsilon_4 + y \sinh[By] \Upsilon_5 \\ & + \epsilon \{ (\Upsilon_6 + \Upsilon_7 \cosh[By] + \Upsilon_8 \cosh[2By] - \Upsilon_9 \cosh[3By] - \Upsilon_{10} \cosh[4By])y^0 \\ & + (-\Upsilon_{11} \sinh[By] + \Upsilon_{12} \sinh[2By] + \Upsilon_{13} \sinh[3By])y \\ & + (-\Upsilon_{14} + \Upsilon_{15} \cosh[By] - \Upsilon_{16} \cosh[2By])y^2 + (-\Upsilon_{17} \sinh[By] + \Upsilon_{18} \sinh[2By])y^3 \\ & + (\Upsilon_{19} + \Upsilon_{20} \cosh[By] - \Upsilon_{21} \cosh[2By])y^4 - (\Upsilon_{22} \sinh[By] + \Upsilon_{23} \sinh[2By])y^5 \\ & + (\Upsilon_{24} + \Upsilon_{25} \cosh[By])y^6 - \Upsilon_{26}y^8 \}, \end{aligned} \quad (39)$$

where Γ_i and Υ_i are constants which are given in appendix.

4. Volume flux, average velocity and shear stress on the plates

The volume flux in the non-dimensional form is given by

$$Q = \int_{-1}^1 u(y) dy. \quad (40)$$

Using Eq. (38) in Eq. (40) we obtain

$$\begin{aligned} Q = & \frac{1}{210B^6} \{ 140B^5 \epsilon \sinh[3B] \Gamma_6 - 210B^5 \epsilon \cosh[2B] \Gamma_8 + 105B^4 \epsilon \sinh[2B] (2B\Gamma_5 + \Gamma_8) \\ & + 420B \epsilon \cosh[B] (B^4 \Gamma_7 + 2B^2 \Gamma_{10} + B(6 + B^2)(B\Gamma_{11} + 4\Gamma_{13}) + (120 + 20B^2 + B^4)\Gamma_{14}) \\ & - 420 \sinh[B] (-B^2 \Gamma_2 + B \epsilon (B^4 \Gamma_4 + B^3 \Gamma_7 + B(2 + B^2)(B\Gamma_{10} + 3\Gamma_{11})) \\ & + (24 + 12B^2 + B^4)\Gamma_{13}) + 5(24 + 12B^2 + B^4)\epsilon \Gamma_{14} \\ & + 4B^6 (7(15\Gamma_0 - 5\Gamma_1 + \epsilon(15\Gamma_3 + 5\Gamma_9 + 3\Gamma_{12})) + 15\epsilon \Gamma_{15}) \}. \end{aligned} \quad (41)$$

The average velocity, \bar{u} , of the couple stress fluid is:

$$\bar{u} = \frac{Q}{H}, \quad (42)$$

which in the non-dimensional form coincides with flow rate given in Eq. (41). The dimensionless shear stress τ_p , on the surface of the upper plate is given by the formula

$$\tau_p = -\tau_{xy}|_{y=1} = -\mu \frac{du}{dy} \Big|_{y=1}. \quad (43)$$

The minus sign accounts for the upper plate facing the negative y-direction of the coordinate system as shown in Fig. 1 (Papanastasiou et al., 2000). Using Eq. (38) in Eq. (43) we have,

$$\begin{aligned} \tau_p = & \mu \{ 2\Gamma_1 - B \sinh[B] \Gamma_2 + \epsilon (-3B \sinh[3B] \Gamma_6 + 2B \cosh[2B] \Gamma_8 \\ & + \sinh[2B] (-2B\Gamma_5 + \Gamma_8) + \sinh[B] (-\Gamma_7 - 3\Gamma_{11} + B(\Gamma_4 + \Gamma_{10} + \Gamma_{13}) - 5\Gamma_{14}) \\ & - \cosh[B] (-2(\Gamma_{10} + 2\Gamma_{13}) + B(\Gamma_7 + \Gamma_{11} + \Gamma_{14})) - 2(\Gamma_9 + 2\Gamma_{12} + 3\Gamma_{15}) \}. \end{aligned} \quad (44)$$

Similarly, shear stress on the lower plate can be calculated.

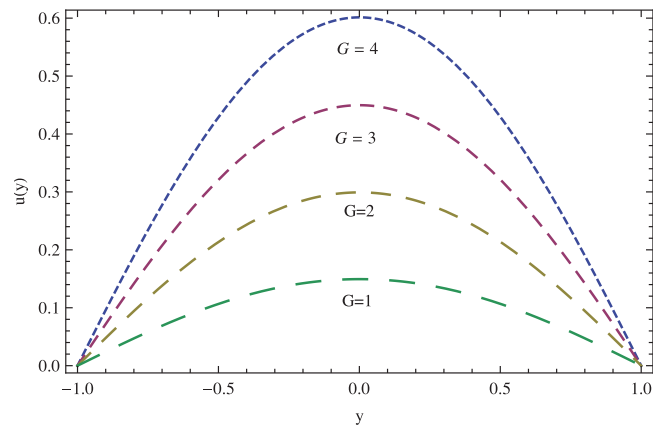

Figure 2 Effect of parameter G on velocity field, $u(y)$, for $B_r = 1$, $m = 3$ and $\epsilon = 0.1$.

5. Results and discussion

In this work, we have studied the heat transfer flow of couple stress fluids between two heated parallel inclined plates. The approximate analytical solutions of velocity field and temper-

ature distribution are obtained by using the perturbation technique. The effect of various non-dimensional parameters on velocity field, temperature distribution, volumetric flow rate and shear stress is investigated graphically as shown below. In Figs. 2 and 3, velocity, u , of the fluid is plotted against

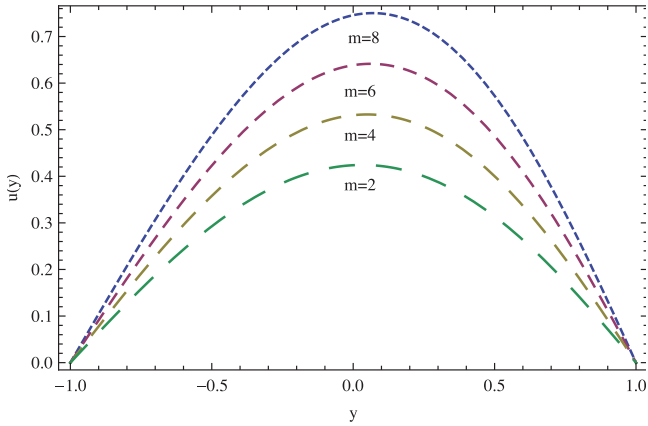

Figure 3 Effect of parameter m on velocity field, $u(y)$, for $B_r = 1$, $G = 4$ and $\epsilon = 0.1$.

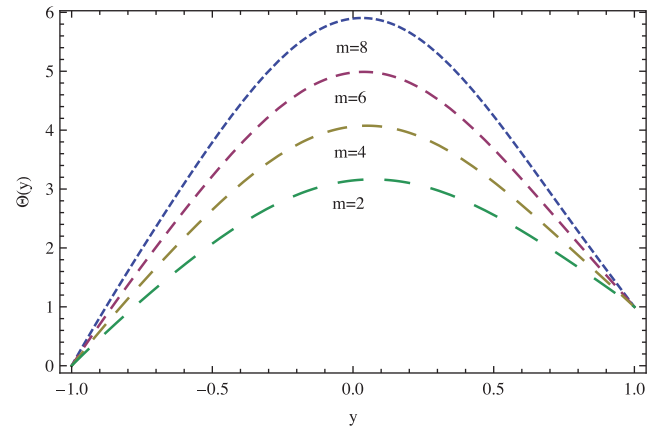

Figure 6 Effect of parameter m on temperature distribution, $\Theta(y)$, for $B_r = 2$, $G = 4$ and $\epsilon = 0.1$.

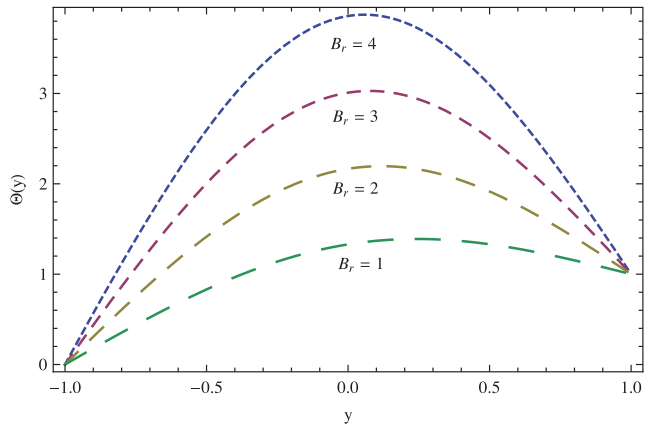

Figure 4 Effect of the Brinkman number, B_r , on temperature distribution, $\Theta(y)$, for $G = 2$, $m = 3$ and $\epsilon = 0.1$.

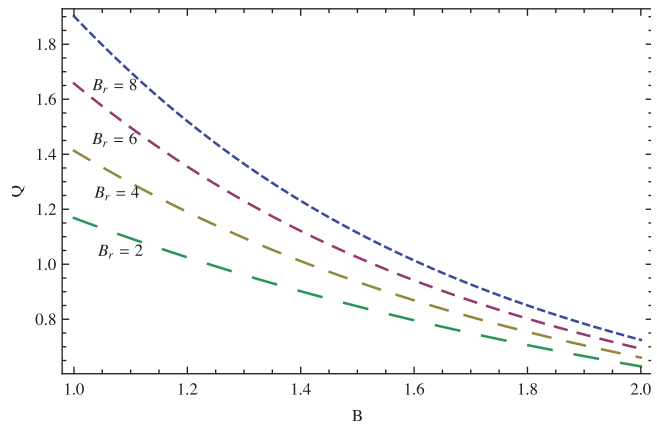

Figure 7 Effect of the Brinkman number, B_r , on flow rate, Q , for $G = 4$, $m = 3$ and $\epsilon = 0.1$.

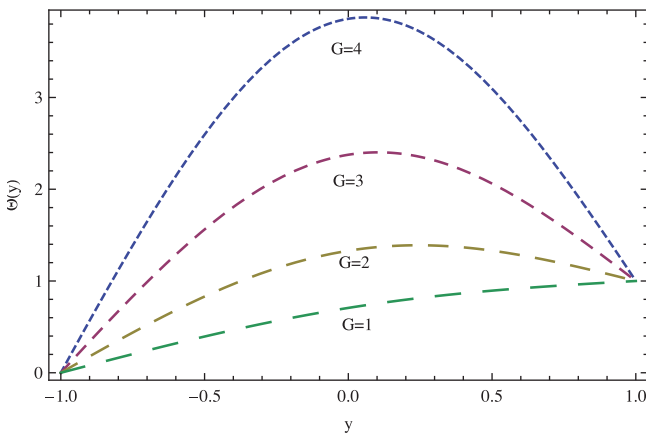

Figure 5 Effect of parameter G on temperature distribution, $\Theta(y)$, for $B_r = 1$, $m = 3$ and $\epsilon = 0.1$.

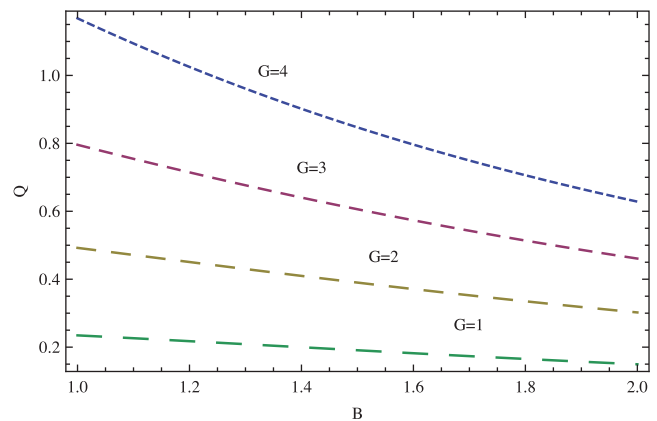

Figure 8 Effect of parameter, G , on flow rate, Q , for $B_r = 2$, $m = 3$ and $\epsilon = 0.1$.

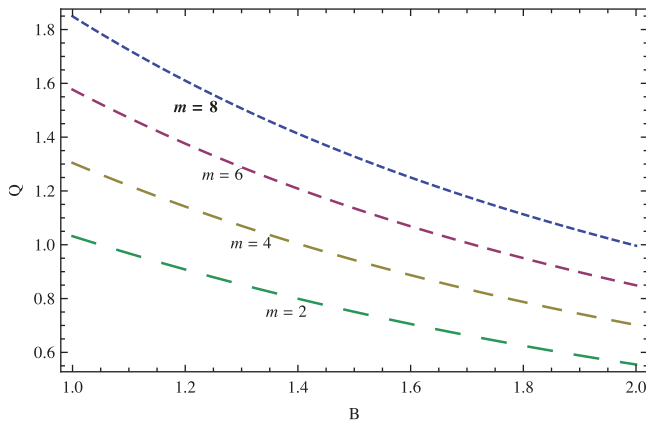

Figure 9 Effect of parameter, m , on flow rate, Q , for $B_r = 2$, $G = 4$ and $\epsilon = 0.1$.

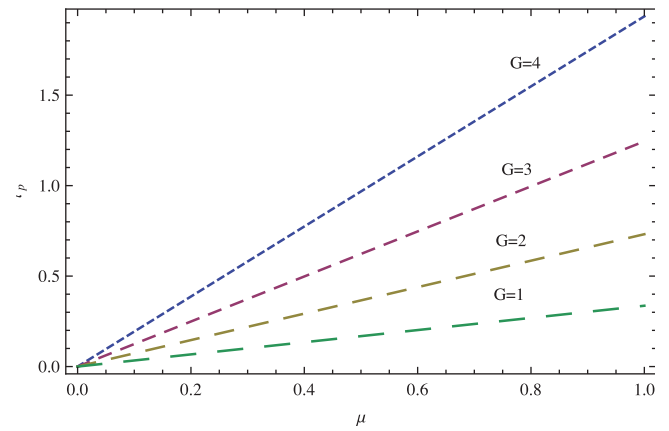

Figure 11 Effect of parameter G on shear stress, τ_p , for $B_r = 2$, $m = 3$ and $\epsilon = 0.1$.

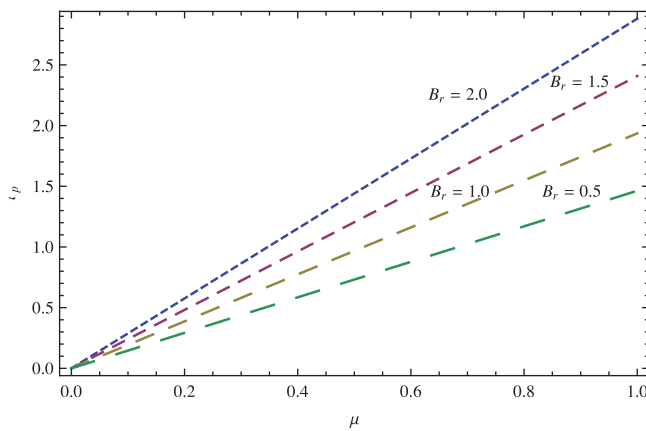

Figure 10 Effect of the Brinkman number, B_r , on shear stress, τ_p , for $G = 4$, $m = 3$ and $\epsilon = 0.1$.

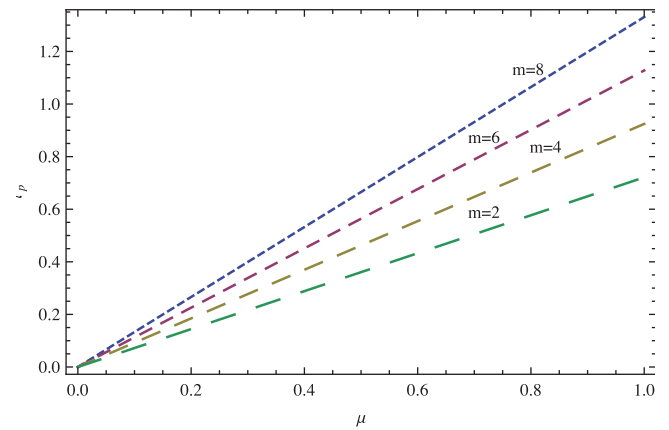

Figure 12 Effect of parameter m on shear stress, τ_p , for $B_r = 1$, $G = 4$ and $\epsilon = 0.1$.

the independent variable y . Both these profiles are parabolic and satisfy the given boundary conditions. These graphs show an increasing behavior of velocity of the fluid by increasing the non-dimensional parameters G and m , respectively.

Figs. 4–6 are plotted to visualize the effect of different parameters on thermal profiles $\Theta(y)$. It can be seen in Fig. 4 that, an increase in B_r increases the temperature of the fluid while Figs. 5 and 6 also depict a direct relation between the temperature distribution $\Theta(y)$ and the dimensionless quantities G and m , respectively. The volume flow rate of the fluid is investigated in Figs. 7–9 and effects of the Brinkman number B_r and parameters G and m can be observed in these figures. In order to observe the behavior of the shear stress τ_p in the Poiseuille flow while changing the values of three parameters B_r , G and m , we have sketched τ_p against the viscosity μ in Figs. 10–12. Again B_r shows a direct relation with τ_p in Fig. 10. Figs. 11 and 12 report that the shear stress is strongly dependent on the physical quantities G and m , respectively. It is clear from the figures that as these parameters increase the shear stress also increases on the plates.

6. Conclusion

In this paper, we have studied the heat transfer flow of couple stress fluids between two heated parallel inclined plates for Reynold's viscosity model. The strongly nonlinear and coupled differential equations are solved with the help of the perturbation technique for fluid velocity and temperature distribution. Analytical expressions for velocity field, temperature distribution, dynamic pressure, volumetric flow rate, average velocity of fluid and shear stress on the plates are obtained. It is shown graphically that velocity, temperature, volume flow rate and shear stress on the plates are strongly dependent on the dimensionless parameters B_r , G and m .

Acknowledgement

The authors are indebted to the anonymous referees for their valuable suggestions/comments on the earlier version of the paper which improved the quality of the paper.

Appendix A.

$$\Gamma_0 = \frac{G}{2B^4}(-2 + B^2), \quad \Gamma_1 = \frac{G}{2B^2}, \quad \Gamma_2 = \frac{G \operatorname{sech}[B]}{B^4},$$

$$\begin{aligned} \Gamma_3 = & \frac{1}{24B^6} m(B^2 \Gamma_2 (-48B \sinh[B](B^2 \Upsilon_1 + 2(6 + B^2) \Upsilon_2) + 4B^4 \cosh[3B] \Upsilon_4 \\ & + 12 \cosh[B](48 \Upsilon_2 + B^2(4(\Upsilon_1 + 6 \Upsilon_2) - B^2(2 \Upsilon_0 - 2(\Upsilon_1 + \Upsilon_2) + \Upsilon_4))) \\ & + 6B^3(-2 + B^2) \Upsilon_5 - 6B^4 \sinh[2B] \Upsilon_5 + 3B^3 \cosh[2B](2B \Upsilon_3 + \Upsilon_5)) + 4\Gamma_1(1440 \Upsilon_2 \\ & + B^2(72 \Upsilon_1 + B(B(6(-2 + B^2) \Upsilon_0 + 3(4 \cosh[B] \Upsilon_3 + \cosh[2B] \Upsilon_4) - B(B(3 \Upsilon_1 + 2 \Upsilon_2) \\ & + 12 \sinh[B](\Upsilon_3 + \cosh[B] \Upsilon_4))) + 12((2 + B^2) \cosh[B] - 2B \sinh[B]) \Upsilon_5))), \end{aligned}$$

$$\Gamma_4 = \frac{m \Gamma_1}{B^4} (-\Upsilon_0 B^4 + 6(B^2 \Upsilon_1 + 20 \Upsilon_2)) - \frac{1}{4} B m \Gamma_2 \Upsilon_5,$$

$$\Gamma_5 = \frac{m \Gamma_1}{2B^2} (\Upsilon_1 B^2 + 20 \Upsilon_2), \quad \Gamma_6 = \frac{1}{3} m \Gamma_1 \Upsilon_2,$$

$$\begin{aligned} \Gamma_7 = & \frac{m \operatorname{sech}[B]}{720B^6} (B^2 \Gamma_2 (-360B^4(2 \cosh[B] + B \sinh[B]) \Upsilon_0 + 135B^4 \cosh[3B] \Upsilon_4 \\ & + 12B \sinh[B](5B^2(-3 + 2B^2) \Upsilon_1 + (-45 + 6B^2(-5 + B^2)) \Upsilon_2 - 15B^4 \Upsilon_4) \\ & + 180 \cosh[B](B^2(8 + B^2) \Upsilon_1 + (96 + 3B^2 + B^4) \Upsilon_2 - 2B^4 \Upsilon_4) - 360B^3 \Upsilon_5 \\ & - 240B^4 \sinh[2B] \Upsilon_5 + 40B^3 \cosh[2B](6B \Upsilon_3 + 5 \Upsilon_5)) + 40\Gamma_1(4320 \Upsilon_2 + B^2(216(\Upsilon_1 + 10 \Upsilon_2) \\ & + B(B(-36(\Upsilon_0 - 3 \Upsilon_1 - 5 \Upsilon_2) - 9((-4 + B^2) \cosh[B] + B \sinh[B]) \Upsilon_3 \\ & + 4(5 \cosh[2B] - 6B \sinh[2B]) \Upsilon_4) + 3(3(8 + B^2) \cosh[B] + B(-3 + 2B^2) \sinh[B]) \Upsilon_5))), \end{aligned}$$

$$\Gamma_8 = \frac{m}{4B^2} (3\Gamma_2(B^2 \Upsilon_1 + 15 \Upsilon_2) + 2B\Gamma_1(B \Upsilon_3 + 3 \Upsilon_5)), \quad \Gamma_9 = \frac{3}{4} m \Gamma_2 \Upsilon_2,$$

$$\Gamma_{10} = \frac{m}{4B^3} (\Gamma_2(-2B^4 \Upsilon_0 + 7B^2 \Upsilon_1 + 93 \Upsilon_2 - B^4 \Upsilon_4) + 2B\Gamma_1(3B \Upsilon_3 + 7 \Upsilon_5)),$$

$$\Gamma_{11} = \frac{m}{6B} (\Gamma_2(B^2 \Upsilon_1 + 21 \Upsilon_2) + 2B\Gamma_1 \Upsilon_5), \quad \Gamma_{12} = \frac{1}{10} B m \Gamma_2 \Upsilon_2,$$

$$\Gamma_{13} = \frac{m}{72B^2} (44\Gamma_1 \Upsilon_4 + B\Gamma_2(6B \Upsilon_3 + 11 \Upsilon_5)), \quad \Gamma_{14} = \frac{m}{12B} (4\Gamma_1 \Upsilon_4 + B\Gamma_2 \Upsilon_5), \quad \Gamma_{15} = \frac{1}{48} m \Gamma_2 \Upsilon_4$$

$$\Upsilon_0 = \frac{1}{12B^2} (6B^2 + B_r(4(6 + B^2) \Gamma_1^2 + 48(\cosh[B] - B \sinh[B]) \Gamma_1 \Gamma_2 + 3B^2 \cosh[2B] \Gamma_2^2)),$$

$$\Upsilon_1 = -\frac{2B_r \Gamma_1^2}{B^2}, \quad \Upsilon_2 = -\frac{1}{3} B_r \Gamma_1^2, \quad \Upsilon_3 = -\frac{4B_r \Gamma_1 \Gamma_2}{B^2}, \quad \Upsilon_4 = -\frac{1}{4} B_r \Gamma_2^2, \quad \Upsilon_5 = \frac{1}{2} + \frac{4B_r \Gamma_1 \Gamma_2}{B},$$

$$\begin{aligned}
Y_6 = & \frac{B_r}{60480B^7} (945B^7 \cosh[4B]\Gamma_2(48\Gamma_6 + m\Gamma_2Y_4) + 560B^5 \cosh[3B](-336\Gamma_1\Gamma_6 \\
& + 4\Gamma_2(18B^2\Gamma_5 - 3B\Gamma_8 + 4m\Gamma_1Y_4) + Bm\Gamma_2^2(3BY_3 + 2Y_5)) - 1680B^6 \sinh[3B](8\Gamma_1(6\Gamma_6 \\
& + m\Gamma_2Y_4) + B\Gamma_2(24\Gamma_8 + m\Gamma_2Y_5)) + 15120B \sinh[B](8\Gamma_1(2640\Gamma_{14} + 2B(216\Gamma_{13} \\
& + B(6(7\Gamma_{11} + 30\Gamma_{14}) + B(10\Gamma_{10} + 28\Gamma_{13} + B(2\Gamma_7 + 4\Gamma_{11} + 6\Gamma_{14} + B(\Gamma_{10} + \Gamma_{13} \\
& + m\Gamma_2Y_0)) - (18 + B^2)m\Gamma_2Y_1)) - (600 + 60B^2 + B^4)m\Gamma_2Y_2) + B^5m\Gamma_2Y_4) \\
& - 16B^2m\Gamma_1^2(4BY_3 + (18 + B^2)Y_5) + B\Gamma_2(16B^4\Gamma_9 + 32B^2(6 + B^2)\Gamma_{12} \\
& + 48(120 + 20B^2 + B^4)\Gamma_{15} + 3B^5m\Gamma_2Y_5)) + 15120B^3 \sinh[2B](\Gamma_2(-15\Gamma_{14} \\
& - B(6\Gamma_{13} + B(3\Gamma_{11} + 10\Gamma_{14} + B(2\Gamma_{10} + 4\Gamma_{13} - 2B(\Gamma_7 + \Gamma_{11} + \Gamma_{14}) + m\Gamma_2Y_1))) \\
& - 2B(3 + B^2)m\Gamma_2Y_2) - 8Bm\Gamma_1^2Y_4 - 2B^2\Gamma_1(4B\Gamma_5 - 2\Gamma_8 + m\Gamma_2(BY_3 + 2Y_5))) \\
& + 72B^5(-4\Gamma_1(140(6 + B^2)\Gamma_9 + 840(\Gamma_{12} + \Gamma_{15}) + B^2(112\Gamma_{12} + 90\Gamma_{15} \\
& + m\Gamma_1(70Y_0 - 28Y_1 - 15Y_2))) + 7B^4m\Gamma_2^2(30Y_0 - 5Y_1 - 2Y_2 + 15Y_4) \\
& + 70B\Gamma_2(48B_r\Gamma_1\Gamma_4\Gamma_8 + B(-12(\Gamma_{10} + \Gamma_{13}) + B(6\Gamma_7 + 3\Gamma_{11} + 2\Gamma_{14} - 2m\Gamma_1Y_5)))) \\
& - 3780B^2 \cosh[2B](8B\Gamma_1(4B^2\Gamma_5 - 4(B + B^3)\Gamma_8 - (3 + 2B^2)m\Gamma_1Y_4) + Bm\Gamma_2^2(-15Y_2 \\
& + B^2(-3(Y_1 + 6Y_2) + 2B^2(Y_0 - Y_1 - Y_2 + Y_4))) + 2\Gamma_2(4B^4\Gamma_4(B + 8B_r\Gamma_1\Gamma_8) - 15\Gamma_{14} \\
& - B(6\Gamma_{13} + B(3(\Gamma_{11} + 10\Gamma_{14}) + 2B(\Gamma_{10} + 6\Gamma_{13} + B(6B\Gamma_6 + \Gamma_7 + 3\Gamma_{11} \\
& - 2B(\Gamma_{10} + \Gamma_{13}) + 5\Gamma_{14}) + 2m\Gamma_1Y_3) + 2(3 + 2B^2)m\Gamma_1Y_5)))) \\
& - 15120 \cosh[B](16\Gamma_1(B^5\Gamma_4 + B^4(4 + B^2)\Gamma_7 + 1440\Gamma_{14} + B(3B^2(4 + B^2)\Gamma_{10} \\
& + B(48 + 18B^2 + B^4)\Gamma_{11} + 240\Gamma_{13} + 96B^2\Gamma_{13} + 5B^4\Gamma_{13} + 600B\Gamma_{14} + 40B^3\Gamma_{14} \\
& + B^5\Gamma_{14} + 2B^4m\Gamma_2Y_0 - 24B^2m\Gamma_2Y_1 - 6B^4m\Gamma_2Y_1 - 720m\Gamma_2Y_2 - 240B^2m\Gamma_2Y_2 \\
& - 10B^4m\Gamma_2Y_2 + B^4m\Gamma_2Y_4)) - 16B^2m\Gamma_1^2(B(6 + B^2)Y_3 + 6(4 + B^2)Y_5) \\
& + B\Gamma_2(5760\Gamma_{15} + B^2(192(\Gamma_{12} + 15\Gamma_{15}) + B^2(16(\Gamma_9 + 6\Gamma_{12} + 15\Gamma_{15}) \\
& + B(-8B\Gamma_5 - 4\Gamma_8 + m\Gamma_2(BY_3 + 6Y_5)))))), \\
Y_7 = & \frac{B_r}{4B^7} (16\Gamma_1(B^5\Gamma_4 + 4B^4\Gamma_7 + 1440\Gamma_{14} + B(12B^2\Gamma_{10} + 48B\Gamma_{11} + 240\Gamma_{13} \\
& + m\Gamma_2(2B^4Y_0 - 24B^2Y_1 - 720Y_2 + B^4Y_4)) - 96B^2m\Gamma_1^2(BY_3 + 4Y_5) \\
& + B\Gamma_2(-8B^6\Gamma_5 - 4B^5\Gamma_8 + 16B^4\Gamma_9 + 192B^2\Gamma_{12} + 5760\Gamma_{15} + B^6m\Gamma_2Y_3 + 6B^5m\Gamma_2Y_5)), \\
Y_8 = & \frac{B_r}{16B^5} (Bm\Gamma_2^2(2B^4Y_0 - 3B^2Y_1 - 15Y_2 + 2B^4Y_4) + 8B\Gamma_1(4B^2\Gamma_5 - 4B\Gamma_8 - 3m\Gamma_1Y_4) \\
& + 2\Gamma_2(4B^5\Gamma_4 - 15\Gamma_{14} - B(6\Gamma_{13} + B(3\Gamma_{11} + 2B(B(6B\Gamma_6 + \Gamma_7) + \Gamma_{10} + 2m\Gamma_1Y_3) \\
& + 6m\Gamma_1Y_5))))), \\
Y_9 = & \frac{B_r}{108B^2} (-336\Gamma_1\Gamma_6 + 4\Gamma_2(18B^2\Gamma_5 - 3B\Gamma_8 + 4m\Gamma_1Y_4) + Bm\Gamma_2^2(3BY_3 + 2Y_5)), \\
Y_{10} = & \frac{B_r\Gamma_2}{64} (48\Gamma_6 + m\Gamma_2Y_4), \\
Y_{11} = & \frac{B_r}{4B^6} (8\Gamma_1(2640\Gamma_{14} + 2B(B^4\Gamma_4 + 216\Gamma_{13} + B(42\Gamma_{11} + B(2B\Gamma_7 + 10\Gamma_{10} \\
& + m\Gamma_2(B^2Y_0 - 18Y_1))) - 600m\Gamma_2Y_2) + B^5m\Gamma_2Y_4) - 32B^2m\Gamma_1^2(2BY_3 + 9Y_5) \\
& + B\Gamma_2(-8B^5\Gamma_8 + 16B^4\Gamma_9 + 192B^2\Gamma_{12} + 5760\Gamma_{15} + 3B^5m\Gamma_2Y_5)), \\
Y_{12} = & \frac{B_r}{4B^4} (\Gamma_2(-2B^4\Gamma_7 + 15\Gamma_{14} + B(6\Gamma_{13} + B(2B\Gamma_{10} + 3\Gamma_{11} + Bm\Gamma_2Y_1) + 6m\Gamma_2Y_2)) \\
& + 8Bm\Gamma_1^2Y_4 + 2B^2\Gamma_1(4B\Gamma_5 - 2\Gamma_8 + m\Gamma_2(BY_3 + 2Y_5))),
\end{aligned}$$

$$\begin{aligned} \Upsilon_{13} &= \frac{B_r}{36B} (8\Gamma_1(6\Gamma_6 + m\Gamma_2\Upsilon_4) + B\Gamma_2(24\Gamma_8 + m\Gamma_2\Upsilon_5)), \\ \Upsilon_{14} &= \frac{B_r}{8B^2} (-32\Gamma_1\Gamma_9 + B^2\Gamma_2(4B\Gamma_7 - 8\Gamma_{10} + B^2m\Gamma_2(2\Upsilon_0 + \Upsilon_4))), \\ \Upsilon_{15} &= \frac{4B_r}{B^5} (6B\Gamma_2(B^2\Gamma_{12} + 30\Gamma_{15}) + \Gamma_1(600\Gamma_{14} + B(B^3\Gamma_7 + 96\Gamma_{13} \\ &\quad + 3B(B\Gamma_{10} + 6\Gamma_{11} - 2Bm\Gamma_2\Upsilon_1) - 240m\Gamma_2\Upsilon_2)) - B^2m\Gamma_1^2(B\Upsilon_3 + 6\Upsilon_5)), \\ \Upsilon_{16} &= \frac{B_r}{8B^3} (\Gamma_2(-4B^3\Gamma_{10} + 30\Gamma_{14} + B(6B\Gamma_{11} + 12\Gamma_{13} + m\Gamma_2(B^2\Upsilon_1 + 9\Upsilon_2))) \\ &\quad + 8Bm\Gamma_1^2\Upsilon_4 + 4B^2\Gamma_1(4\Gamma_8 + m\Gamma_2\Upsilon_5)), \\ \Upsilon_{17} &= \frac{4B_r}{B^4} (2B\Gamma_2(B^2\Gamma_{12} + 30\Gamma_{15}) + \Gamma_1(B^3\Gamma_{10} + 180\Gamma_{14} + B(4B\Gamma_{11} + 28\Gamma_{13} \\ &\quad - m\Gamma_2(B^2\Upsilon_1 + 60\Upsilon_2))) - B^2m\Gamma_1^2\Upsilon_5), \\ \Upsilon_{18} &= \frac{B_r\Gamma_2}{2B^2} (5\Gamma_{14} + B(-B\Gamma_{11} + 2\Gamma_{13} + m\Gamma_2\Upsilon_2)), \\ \Upsilon_{19} &= \frac{B_r}{24B^2} (8B^2m\Gamma_1^2\Upsilon_0 + B^2\Gamma_2(-6B\Gamma_{11} + 24\Gamma_{13} + B^2m\Gamma_2\Upsilon_1) \\ &\quad + 4\Gamma_1(4B^2\Gamma_9 + 24\Gamma_{12} + B^3m\Gamma_2\Upsilon_5)), \\ \Upsilon_{20} &= \frac{4B_r}{B^3} (15B\Gamma_2\Gamma_{15} + \Gamma_1(40\Gamma_{14} + B(B\Gamma_{11} + 5(\Gamma_{13} - 2m\Gamma_2\Upsilon_2)))), \\ \Upsilon_{21} &= \frac{B_r\Gamma_2}{8B} (-4B\Gamma_{13} + 10\Gamma_{14} + Bm\Gamma_2\Upsilon_2), \\ \Upsilon_{22} &= \frac{4B_r}{B^2} (3B\Gamma_2\Gamma_{15} + \Gamma_1(B\Gamma_{13} + 6\Gamma_{14} - Bm\Gamma_2\Upsilon_2)), \quad \Upsilon_{23} = \frac{1}{2}B_r\Gamma_2\Gamma_{14}, \\ \Upsilon_{24} &= \frac{B_r}{60B^2} (16\Gamma_1(2B^2\Gamma_{12} + 15\Gamma_{15}) - 8B^2m\Gamma_1^2\Upsilon_1 + B^3\Gamma_2(-10\Gamma_{14} + Bm\Gamma_2\Upsilon_2)), \\ \Upsilon_{25} &= \frac{4B_r\Gamma_1\Gamma_{14}}{B}, \quad \Upsilon_{26} = \frac{1}{14}B_r\Gamma_1(-6\Gamma_{15} + m\Gamma_1\Upsilon_2). \end{aligned}$$

References

- Aksoy, Y., Pakdemirli, M., 2010. Approximate analytical solutions for flow of a third-grade fluid through a parallel-plate channel filled with a porous medium. *Transport in Porous Media* 83, 375–395.
- Chen, C.L., Chen, C.K., Yang, Y.K., 2004. Unsteady unidirectional flow of an Oldroyd-B fluid in a circular duct with different given volume flow rate. *International Journal of Heat and Mass Transfer* 40, 203–209.
- Chinyoka, T., Makinde, O.D., 2011. Analysis of transient Generalized Couette flow of a reactive variable viscosity third-grade liquid with asymmetric convective cooling. *Mathematical and Computer Modelling* 54, 160–174.
- El-Dabe, N.T.M., El-Mohandis, S.M.G., 1995. Effect of couple stresses on pulsatile hydromagnetic Poiseuille flow. *Fluid Dynamics Research* 15, 313–324.
- El-Dabe, N.T.M., Hassan, A.A., Mohamed, Mona A.A., 2003. Effect of couple stresses on pulsatile hydromagnetic Poiseuille flow. *Zeitschrift für Naturforschung* 58a, 204–210.
- Ellahi, R., 2009. *Steady and Unsteady Flow Problems for Newtonian and Non-Newtonian Fluids: Basics, Concepts, Methods*. VDM Verlag, Germany.
- Farooq, M., Islam, S., Rahim, M.T., Haroon, T., 2011. Heat transfer flow of steady couple stress fluids between two parallel plates with variable viscosity. *Heat Transfer Research* 42 (8), 737–780.
- Farooq, M., Islam, S., Rahim, M.T., Siddiqui, A.M., 2012. Laminar flow of couple stress fluids for Vogel's model. *Scientific Research and Essays* 7 (33), 2936–2961.
- Fetecau, C., Fetecau, C., 2002. The Rayleigh–Stokes problem for heated second grade fluids. *International Journal of Non-Linear Mechanics* 37, 1011–1015.
- Fetecau, C., Fetecau, C., 2003. Decay of a potential vortex in a Maxwell fluid. *International Journal of Non-Linear Mechanics* 28, 985–990.
- Fetecau, C., Fetecau, C., 2005. Decay of a potential vortex in an Oldroyd-B fluid. *International Journal of Engineering Science* 43, 340–351.
- Islam, S., Zhou, C.Y., 2007. Exact solutions for two-dimensional flows of couple stress fluids. *ZAMP* 58, 1035–1048.
- Islam, S., Ishtiaq Ali, Ran, X.J., Shah, A., Siddiqui, A.M., 2009. Effects of couple stresses on Couette and Poiseuille flow. *International Journal of Non-linear Sciences and Numerical Simulations* 10 (1), 99–112.
- Makinde, O.D., 2006. Laminar falling liquid film with variable viscosity along an inclined heated plate. *Applied Mathematics and Computation* 175, 80–88.
- Makinde, O.D., 2009. Thermal criticality for a reactive gravity driven thin film flow of a third grade fluid with adiabatic free surface down an inclined plane. *Applied Mathematics and Mechanics* 30 (3), 373–380.
- Makinde, O.D., 2010. Thermodynamic second law analysis for a gravity-driven variable viscosity liquid film along an inclined heated plate with convective cooling. *Journal of Mechanical Science and Technology* 24 (4), 899–908.
- Massoudi, M., Christie, I., 1995. Effects of variable viscosity and viscous dissipation on the flow of a third grade fluid in a pipe. *International Journal of Non-Linear Mechanics* 30, 687–699.
- Papanastasiou, T.C., Georgiou, G.C., Alexandrou, A.N., 2000. *Viscous Fluid Flow*. CRC Press, USA.
- Reynolds, O., 1886. On the theory of lubrication and its application to Mr. Beuchamp Tower's experiment, including an experimental determination of the viscosity of olive oil. *Philosophical Transactions of the Royal Society* 177, 157–234.
- Shah, R.A., Islam, S., Siddiqui, A.M., Haroon, T., 2011. Heat transfer by laminar flow of a third grade fluid in wire coating analysis with temperature dependent and independent viscosity. *Analysis and Mathematical Physics* 1, 147–166.

- Siddiqui, A.M., Ahmed, M., Ghori, Q.K., 2006. Couette and Poiseuille flows for non-Newtonian fluids. *International Journal of Non-linear Sciences and Numerical Simulations* 7 (1), 15–26.
- Siddiqui, A.M., Zeb, A., Ghori, Q.K., Benharbit, A.M., 2008. Homotopy perturbation method for heat transfer flow of a third grade fluid between parallel plates. *Chaos Solitons and Fractals* 36, 182–192.
- Srinivasacharya, D., Kaladhar, K., 2011. Analytical solution of MHD free convective flow of couple stress fluid in an annulus with Hall and Ion-slip effects. *Nonlinear Analysis: Modelling and Control* 16 (4), 477–487.
- Stokes, V.K., 1966. Couple stresses in fluid. *Physics of Fluids* 9, 1709–1715.
- Stokes, V.K., 1984. *Theories of Fluids with Microstructure: An Introduction*. Springer-Verlag, New York.
- Szeri, A.Z., Rajagopal, K.R., 1985. Flow of a non-Newtonian fluid between heated parallel plates. *International Journal of Non-Linear Mechanics* 20, 91–101.
- Tan, W.C., Masuoka, T., 2005a. Stokes' first problem for a second grade fluid in a porous half space with heated boundary. *International Journal of Non-Linear Mechanics* 40, 515–522.
- Tan, W.C., Masuoka, T., 2005b. Stokes' first problem for an Oldroyd-B fluid in a porous half space. *Physics of Fluids* 17, 023101–023107.
- Tan, W.C., Xu, M.Y., 2002. The impulsive motion of a flat plate in a generalized second grade fluid. *Mechanics Research Communications* 29, 3–9.
- Tsai, C.Y., Novack, M., Roffle, G., 1988. Rheological and heat transfer characteristics of flowing coal–water mixtures, Final report. DOE/MC/23255-2763.
- Yurusoy, M., Pakdemirli, M., 2002. Approximate analytical solutions for the flow of a third grade fluid in a pipe. *International Journal of Non-Linear Mechanics* 37 (2), 187–195.