



Blockchain and AI/ML Synergy in Healthcare

Sachin Kumar¹, Shitalkumar Jain² and Rohit Lade^{1,3}

¹*School of Computer Engineering, MIT Academy of Engineering, Pune, India*

²*School of Computer Engineering, MIT Academy of Engineering, Pune, India*

³*School of Computer Engineering, MIT Academy of Engineering, Pune, India*

Abstract: The paper delves into the synergy between blockchain technology and Artificial intelligence and machine learning (AIML) tools in healthcare information exchange, with a focus on privacy-preserving data visualization. Acknowledging patients' ownership of healthcare data and the imperative to maintain confidentiality, the study addresses challenges in data analysis for governmental bodies. To overcome this, the paper proposes integrating AIML tools with blockchain networks, leveraging blockchain's decentralized nature and AIML's analytical capabilities. Patients retain control over their data, ensuring confidentiality and access control. The paper outlines the implementation process, highlighting challenges and mitigation strategies. It discusses limitations, including technical complexities and regulatory constraints, and presents results demonstrating the framework's efficacy in preserving privacy while enabling data visualization. Future research directions include scalability improvements and regulatory frameworks. Ultimately, the paper emphasizes the transformative potential of blockchain-AIML collaboration in fostering a transparent, patient-centric healthcare ecosystem, aligning cutting-edge technology with privacy and security imperatives. Additionally, the study explores various use cases and real-world applications of the proposed framework, showcasing how it can be adapted to different healthcare scenarios. By integrating blockchain and AIML, the paper underscores the importance of interdisciplinary approaches in addressing contemporary healthcare challenges. The collaborative efforts of stakeholders, including technologists, healthcare professionals, and policymakers, are crucial for the successful adoption and implementation of this innovative framework.

Keywords: AWS, Etherscan, Healthcare, IPFS, LangChain, LLM, Smart Contracts, study, technology

1. INTRODUCTION

In recent years, the world has faced unprecedented challenges due to the COVID-19 pandemic. During this critical period, the significance of maintaining accurate and accessible medical histories for individual patients became increasingly apparent. Following extensive study and research, it became evident that traditional databases were insufficient in effectively managing patient data. The inherent limitations of these databases, including their vulnerability to security breaches and the lack of granular control over data access, raised significant concerns within the healthcare community.

In response to these challenges, a transition to a blockchain network was deemed imperative. Blockchain technology heralds a paradigm shift in data management by providing a decentralized and immutable ledger system[1]. This revolutionary approach ensures heightened security and transparency in storing patient records. Moreover, blockchain empowers patients with the ability to selectively grant access to their data, thereby safeguarding their privacy and confidentiality[2]. Recognizing the need for a comprehensive solution, we have studied an initial prototype: "Health Information Exchange using Blockchain." This innovative platform aims to securely store and facilitate

the exchange of patient records, ensuring data integrity and privacy while promoting seamless collaboration among healthcare providers[3]. Through this initiative, we seek to harness the transformative potential of blockchain technology to revolutionize healthcare data management and delivery, ultimately enhancing patient care outcomes and advancing the field of medical informatics.

With the burgeoning expansion of artificial intelligence (AI) and machine learning (ML) technologies, it became evident that integrating these systems could significantly enhance our capabilities[4]. Recognizing this opportunity, we identified the potential for collaboration between AI/ML and healthcare systems to offer improved visualization of population trends, including births, deaths, and disease prevalence, while safeguarding the confidentiality of individual patient data[5]. This strategic integration enables us to provide comprehensive insights into healthcare dynamics without compromising the privacy of patients. By leveraging AI/ML algorithms, we can analyze vast datasets to uncover hidden patterns and trends, shedding light on underlying issues within the healthcare sector [5], [6]. This proactive approach empowers us to develop sustainable solutions aimed at addressing systemic challenges and enhancing healthcare outcomes. Through this collaborative endeavor,



we aspire to contribute to the advancement of public health initiatives while upholding the principles of data privacy and ethical practice. By harnessing the synergies between AI/ML technologies and healthcare systems, we strive to foster innovation and drive positive change in the healthcare landscape . This paper is intended to enhance readers' knowledge and understanding of the subject matter. It aims to provide a comprehensive overview, facilitate informed decision-making, and offer insights into ongoing trends in the field. It is hoped that this research will contribute to the body of knowledge in this area and serve as a valuable resource for future research endeavors.

The research paper is structured into multiple sections. Section I serves as an introduction, providing a historical background, presenting the fundamental concepts of the technology under examination, and outlining the scope of the study. Section II offers a comprehensive summary of the research methodology as well as the motivation and need for the current work in the healthcare sector, along with a concise overview of related works within the same technology domain. Section III delves into the specifics of the implementation, offering a comprehensive account of what has been executed. Further, Section IV has a discussion and a comparative analysis of various systems. Subsequently, the following section explores potential future developments and enhancements to the system.

2. MOTIVATION

As we were building a healthcare information sharing platform, we noticed the critical need to improve its usefulness by including artificial intelligence and machine learning (AI/ML)[7]. While a simple healthcare information exchange system can securely store patient records and regulate access, it cannot analyze the data. This constraint is a significant impediment, particularly when considering the government's perspective, which requires insights generated from demographic data such as gender, age, and location. Such a study is critical to developing future healthcare strategies and policies. Integrating AI/ML technologies into the system is critical because they provide the capacity to rapidly handle and analyze large volumes of data [8]. We can generate useful insights from healthcare data within the system using AI and ML. This allows us to discover demographic trends, patterns, and correlations, helping decision-makers make more informed decisions about healthcare planning and budget allocation [9]. Furthermore, the capacity to examine data in real time enables more proactive management of healthcare resources. For example, AI/ML can forecast disease outbreaks based on past data and current patterns, allowing healthcare providers and government organizations to respond quickly and efficiently. This predictive power is extremely useful in preventing and controlling public health emergencies. Furthermore, combining AI and ML can greatly enhance patient outcomes. Individual patient data may be used alongside wider demographic patterns to create personalized treatment approaches. This not only improves the quality of treatment offered, but it

also guarantees that resources are allocated efficiently. For example, AI algorithms can identify individuals who are at high risk for specific disorders and offer preventative measures or early interventions, minimizing the total strain on the healthcare system. Furthermore, incorporating AI/ML into healthcare information sharing systems simplifies compliance with regulatory requirements and standards. By automating data analysis and reporting, these tools enable healthcare practitioners to follow the most recent recommendations and best practices. This not only improves the quality of service, but also reduces the possibility of legal and financial consequences for noncompliance. In summary, including AI/ML technology transforms the healthcare information exchange platform from a simple data store to a formidable instrument for data-driven decision-making and policy creation. It revolutionizes the way healthcare data is used, changing the emphasis from static data storage to dynamic analysis and actionable insights. This paradigm change is crucial for enhancing healthcare systems and increasing public health outcomes as a whole.

3. RESEARCH

After conducting thorough research and analysis, we have identified several crucial key points that will significantly inform our system architecture design process. These key points serve as fundamental pillars upon which we will build our system's framework and functionality. By integrating these insights, we aim to develop a robust and scalable architecture that aligns with our project objectives and user requirements. Our study has given us a thorough grasp of the important factors that must be addressed to ensure the success of our system. These insights cover a wide variety of technical and operational factors, each of which contributes significantly to the overall design. By methodically combining these critical factors, we will provide a solid basis for our system, guaranteeing that it can fulfill its users' different demands while maintaining high performance, security, and dependability. Furthermore, our commitment to incorporating these ideas demonstrates our desire to build a system that is not just technically solid, but also user-centric and future-proof. We understand that a successful system design must be versatile and robust, able to develop alongside evolving technology and user expectations.

A. Challenges of using AI in health record systems:

Large training data requirements, algorithm portability, and scaling complexity is one of the obstacles to AI use in health records . Because labeled data is essential for deep learning, there are practical challenges because of resource limitations and privacy concerns . This need may be reduced by using cutting-edge methods like active learning and picture data improvement [9]. Blockchain and AI integration is not without its difficulties, including privacy concerns and performance snags . In order to fully realize AI's promise to transform health record management and improve patient outcomes, several obstacles must be overcome.

B. Blockchain technology can be used for data management in electronic medical records:

The decentralized, immutable environment that blockchain technology provides for data sharing and storage, which helps to protect the integrity and security of electronic medical records (EMRs) [10]. Without the need for middlemen, smart contracts automate processes like access control. Every transaction can be tracked thanks to its openness and cryptography characteristics, which also ensure data traceability and audits for legal access [10], [11]. All things considered, blockchain offers a strong solution for EMR data management, resolving issues with audit trails, security, and privacy that are common in conventional systems

C. potential solution for improving transparency in machine learning algorithms:

Saliency and heatmaps are two interpretability strategies that may be used to increase transparency in machine learning algorithms and make complex models easier to grasp [11]. These techniques improve the interpretability of algorithms by helping to categorize clinical terminology and produce visual representations of medical pictures. User trust is increased by initiatives to improve interpretability and openness. Transparency is further enhanced by creating methods for interpreting deep learning predictions and by using outside validation techniques [11], [12]. These initiatives are critical, especially in the healthcare industry, where patient trust is crucial.

D. Research trends in the integration of IoT, blockchain, and ML in healthcare:

Exploring applications like illness diagnosis and remote patient monitoring is one of the key research themes in integrating IoT, blockchain, and ML technologies into healthcare [13]. Blockchain and machine learning integration improve EHR security and permit safe medical data transfer. IoT solutions for digitizing clinical information are secured by blockchain, and machine learning helps with risk assessment and therapy [14]. Research trends indicate a rise in interest in networking, storage, and security concerns, especially in light of the COVID-19 pandemic [15]. The overall goals of utilizing these technologies are to improve patient care, data security, and healthcare services.

E. Interest in IoT, blockchain, and ML in healthcare grew, particularly due to the COVID-19 pandemic.

Since 2020, there has been a rush in research in the fields of IoT, blockchain, and machine learning (ML) in healthcare, mostly as a result of the COVID-19 pandemic [16], [17]. Applications such as data management, remote monitoring, and illness detection are being investigated for these technologies. The goal of integration initiatives is to improve technical services and patient care by addressing difficulties related to data security and connectivity [18]. All things considered, the increasing interest in these technologies highlights their potential to enhance healthcare outcomes and services, especially in response to problems brought on by pandemics.

F. How can blockchain and machine learning be used to address security challenges in smart transportation of Data Sharing?

Blockchain and machine learning (ML) can improve security in smart transportation by enabling safe, privacy-preserving data sharing and analysis. Integrating these technologies allows for creative applications such as traffic congestion prediction and intelligent rail system control. One method is Hassija et al.'s proposed blockchain-based secure crowdsourcing paradigm, which combines neural network-based smart contracts and blockchain [19]. This model employs crowdsourced data to provide reliable traffic forecasts using LSTM and feed-forward ANN models. In train systems, Hua et al. proposed leveraging blockchain smart contracts to ensure data exchange among operators, in conjunction with distributed ML optimizing SVMs based on historical data. This connection enables safe, private data exchange, accurate traffic forecasts, and scalable machine learning models, dramatically improving the security and privacy of smart transportation networks.

G. Integrating blockchain and machine learning in health-care management systems presents potential benefits and challenges.

The use of blockchain and machine learning into health-care management systems has various potential benefits and drawbacks. The possible benefits include improved data security, medical care, and operational efficiency. Blockchain technology creates a decentralized, tamper-resistant ledger that protects the integrity and privacy of medical information. It also allows for secure sharing of medical data while retaining data ownership and management. Machine learning enables tailored treatment plans, predictive analytics, and clinical decision support, resulting in better diagnoses, treatment strategies, and patient outcomes. However, there are also challenges associated with this integration. Technical challenges include scalability of blockchain networks and ensuring the accuracy of machine learning models in a healthcare context. Ethical considerations, such as data consent and transparency, need to be addressed to build trust among patients, practitioners, and researchers. Additionally, regulatory challenges and interoperability issues may pose barriers to adoption. Addressing these challenges will be crucial to realizing the full potential of integrating blockchain and machine learning in healthcare management systems. Future research could focus on optimizing hybrid Blockchain-Machine Learning systems and developing standardized protocols for secure data exchange [20].

H. Blockchain technology enhance healthcare data management functions

Blockchain technology improves healthcare data management by solving basic challenges such as data transparency, flexible access, immutability, privacy, audit, traceability, data provenance, trust, and security. It has the ability to improve data efficiency and establish confidence in healthcare data management systems. Healthcare businesses may modernize to become more productive, coordinated,

and user-centered by embracing blockchain technology. The solution creates a secure and decentralized ledger for storing and exchanging medical records, assuring data integrity and privacy protection. Furthermore, blockchain technology makes it easier to construct smart contracts on an Ethereum-based blockchain, improving access control and code obfuscation, and thereby increasing security using cryptographic approaches[21]. Furthermore, blockchain technology can address the issues posed by the growing volume of data in healthcare, particularly in the context of IoT solutions, by giving doctors and third parties with safe, interoperable, and efficient access to medical data. Overall, blockchain technology provides a strong solution for protecting healthcare data, maintaining privacy, and improving healthcare efficiency and quality.

I. Blockchain technology can be utilized for patient data management in the healthcare domain.

Blockchain technology may be used to handle patient data in the healthcare area in a variety of ways. For starters, it may boost security and cost-effectiveness by offering a tamper-proof, sharing platform for medical records. This enables detailed, customized, and secure access to medical data, giving patients choice over their treatment and providing rigorous consent processes for data sharing between institutions and applications. Furthermore, blockchain technology may streamline and combine a variety of operations, increasing the system's speed, agility, and efficiency. It also gives users with role-based control, allowing them to access specified tasks and monitor healthcare-related actions. Furthermore, blockchain technology improves the stability and robustness of the healthcare system by providing secure and simple user interfaces, remote updates of medical information, and continuous availability of system resources[22]. Furthermore, blockchain technology solves issues of data access and interchange, offering solutions for safe data transmission, data security, and privacy in healthcare IoT contexts. It also provides a high-level framework for safe communication and data sharing, allowing patients to securely engage with multiple stakeholders while also aggregating their health data in a sustainable manner. Blockchain technology also provides a decentralized, immutable, and secure platform for sharing and storing electronic medical records, clinical trial data, and insurance information, among other healthcare-related applications.

J. How do machine learning (ML) algorithms integrate with H-IoT systems for healthcare applications?

Machine learning (ML) algorithms connect with Healthcare Internet of Things (H-IoT) systems, acting as the foundation for data processing and decision-making in the healthcare industry. These systems, which are outfitted with various sensors and gadgets, collect health-related information from patients, such as vital signs and activity levels. ML algorithms process enormous amounts of data, recognizing patterns, generating predictions, and delivering insights that raw data cannot. They use supervised and unsupervised learning methodologies to train on labeled

data and find hidden patterns in unlabeled data, respectively. Various machine learning methods, such as Decision Trees, Gradient Boosted Machines, Neural Networks, and Reinforcement Learning, are used to diagnose diseases, anticipate future health hazards, and manage epidemics[23]. They also help with the diagnosis and prognosis of ailments such as cardiovascular problems, neurological diseases, and diabetes, which improves patient care management. Furthermore, ML-IoT systems help those with impairments and the elderly by providing individualized care and cognitive automation. Continuous monitoring of health problems, particularly for chronic illness management and baby health monitoring, is another key advantage. In healthcare logistics, machine learning optimizes medical supply delivery, anticipates emergency department crowds, and increases operational efficiency. Furthermore, putting ML models closer to end devices via edge and fog computing decreases server load and provides low latency answers. Machine learning algorithms improve the security and privacy of sensitive patient data. Overall, ML algorithms are vital to H-IoT systems; they enable sophisticated data processing, help clinical decision-making, and improve healthcare.

4. METHODOLOGY

This technique describes a complete approach to investigating the synergy between Blockchain and AI/ML in the healthcare industry, with a particular emphasis on the interactions of four main stakeholders: patients, hospitals, administrators, and insurance companies. The key goal is to build a safe, efficient, and user-friendly environment in which various stakeholders can work together effortlessly. These interactions will be facilitated via a web-based user interface (UI), which is intended to enable easy access to numerous activities and services. To ensure accessibility and usability across varied language backgrounds, LLM's strong AI capabilities will be used in the web-based user interface. This connection will facilitate multilingual interactions, enabling users to converse and obtain information in their preferred language. LLM's model will not only parse natural language but will also give real-time support and replies, improving the user experience and guaranteeing that language obstacles do not prevent productive conversation. In addition, the system will integrate AI/ML technologies to derive useful insights from user interactions and data. By examining patterns and trends in patient records, treatment results, and other pertinent data, AI/ML models will offer actionable insights that can be used to inform decision-making for all stakeholders. For example, predictive analytics may assist in predicting patient demands, improving hospital resource allocation, and detecting and preventing false insurance claims. Overall, this technique seeks to build a strong, transparent, and intelligent healthcare ecosystem in which blockchain protects data integrity and security while AI/ML improves operational efficiency and patient care through smart data analysis and multilingual assistance. This technique delivers a complete framework for integrating Blockchain and AI/ML in healthcare, with an emphasis on safe, multilingual interactions among different

stakeholder's.

Below is the activity of different stakeholder's. Which helps us to understand the whole system i'e how data flows into the system for each stakeholder's

A. Admin:

The methodology for the admin stakeholder in the study on Blockchain and AI/ML synergy in healthcare is designed to provide secure and efficient administration of interactions between patients, hospitals, and insurance companies. The system is accessed by the administrator via a secure web-based user interface that provides extensive administration and oversight capabilities. The administrator's key responsibilities include adding and deleting hospitals, controlling user access and permissions, and monitoring system activity. They have read-only access to all blockchain data and can interact with files hosted on IPFS and AWS, allowing for decentralized and scalable data management. The system is evaluated by conducting surveys to determine the correctness of AI/ML models, system response times, and user happiness. Pilot testing is carried out to check administrative functions and gain input for future improvements. A feedback loop that integrates user feedback as well as technology improvements enables continuous improvement. This organized method enables the administrator to efficiently manage the healthcare system by integrating Blockchain, AI/ML, IPFS, and AWS to ensure safe, efficient, and transparent interactions between all stakeholders while ensuring data integrity and regulatory compliance. This suggested can be seen in figure 1.

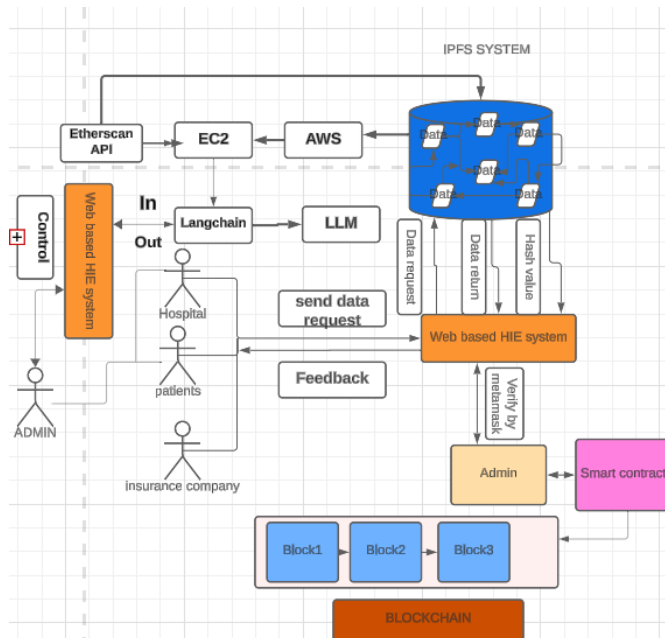

Figure 1. Data Flow for Admin

B. Patients:

The approach for the patient stakeholder in the healthcare information exchange (HIE) system focuses on giving

secure, quick access to full health records via a web-based interface. Patients may engage with the system in their native language, thanks to natural language processing capabilities provided by AI/ML. This technology enables people to monitor their own health, manage crises, and simplify insurance claims. Patients can use the system via a secure online interface. The use of blockchain technology assures the integrity and security of health records, as each transaction is immutably recorded on the blockchain. Smart contracts automate operations such as patient identification verification, insurance claim processing, and hospital data access requests. Decentralized storage via IPFS provides the availability and security of health records, with hash values referenced in the blockchain for verification. AWS offers scalable cloud storage options that ensure patient data is easily available when needed. The system provides various vital functions to patients. They may see and manage their own health data, get AI-powered health insights and suggestions, and engage with healthcare practitioners in their preferred language this can be preview in Figure 2. In an emergency, hospitals can instantly obtain patient information, guaranteeing prompt and correct treatment. In addition, the technology simplifies the insurance claim process by supplying insurance companies with validated health information. Security and privacy are top priorities in the system's architecture. Data is encrypted before being stored on the blockchain or IPFS, and role-based access control guarantees that only authorized users have access to important information. An immutable audit record of all transactions is kept to ensure openness and accountability. Compliance with HIPAA and other healthcare data standards is vigorously enforced.

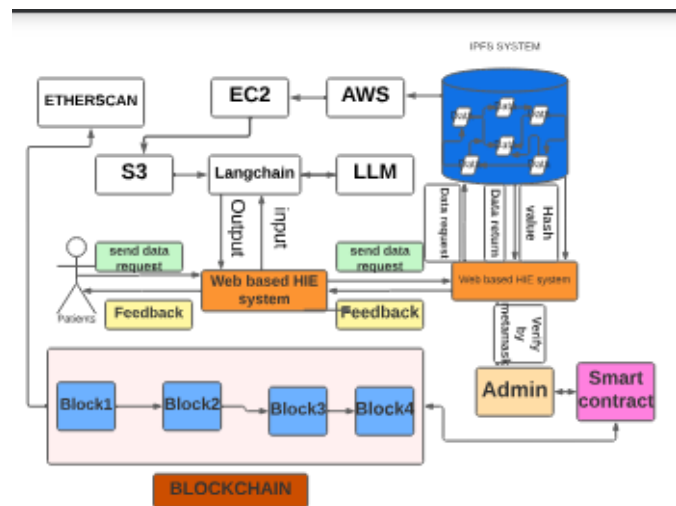

Figure 2. Data Flow for Patient

C. Hospital:

The approach for the hospital stakeholder in the healthcare information exchange (HIE) system focuses on expediting patient registration, providing access to detailed

medical histories, and facilitating timely treatment. The solution improves emergency treatment, assures consistent patient record access across several sites, and offers real-time business analytics to hospital administrators. Hospitals have access to the HIE system via a secure web-based interface. They can register patients with their consent while adhering to privacy standards this can be seen in Figure3. Upon enrollment, hospitals have access to the patient’s medical history, which is kept on a private blockchain for data integrity and security. This full perspective of a patient’s medical history allows healthcare personnel to give prompt and appropriate treatment, which is especially important in emergency situations. The technology also enables patient movement. When a patient relocates, their medical records are available to all hospitals in the network. This continuity of care guarantees that patients receive consistent and educated care regardless of their geographic location.

In terms of commercial operations, the HIE system offers powerful capabilities for hospital administration. The web-based user interface allows hospital managers to request a variety of data and insights. Unlike traditional business intelligence (BI) tools, which can cause delays and sophisticated data processing, the solution provides real-time insights. Administrators may create graphs and reports on patient visits, treatment outcomes, and other key parameters for business success. These real-time data allow hospitals to make more informed decisions, enhance resource allocation, and increase overall operational efficiency. The inclusion of AI/ML models expands the system’s capabilities. AI-powered analytics enable hospitals to forecast patient patterns, manage workloads, and find areas for improvement. Natural language processing with LLM API enables medical personnel to communicate with the system in an easy manner, asking questions and obtaining actionable information in real time.

D. Insurance Company:

The method for the insurance company stakeholder in the healthcare information exchange (HIE) system is centered on providing safe access to medical data with patient agreement, streamlining the claims process, and avoiding fraudulent claims. The use of blockchain technology maintains data integrity, making it impossible to change medical histories, increasing the dependability and security of patient information.

Insurance firms can use the HIE system via a secure web-based interface. They can examine the patient’s medical history if they have their consent, which is maintained on a private blockchain. The unchangeable nature of blockchain technology prevents medical records from being edited or tampered with, making it a reliable source of information. This consistent access to precise patient data allows insurance companies to process claims swiftly and properly, ensuring that patients receive the benefits to which they are entitled without undue delay.

One of the most notable benefits of this technology is its capacity to detect fraudulent activity. Individuals cannot alter their medical history in order to make false insurance claims since blockchain data are immutable. This function protects insurance firms from false claims, lowering financial losses while protecting the integrity of the insurance process this can be seen in figure4.

The method not only prevents fraud, but it also speeds the claims procedure. Insurance companies can swiftly check the validity of claims by comparing the patient’s medical history to the treatments and procedures reported. This simplified verification procedure decreases the time and effort necessary to process claims, hence increasing operational efficiency and customer satisfaction.

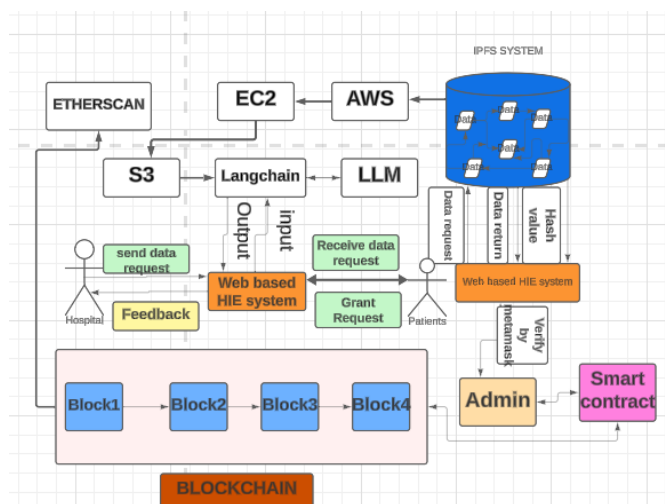

Figure 3. Data Flow for Hospital

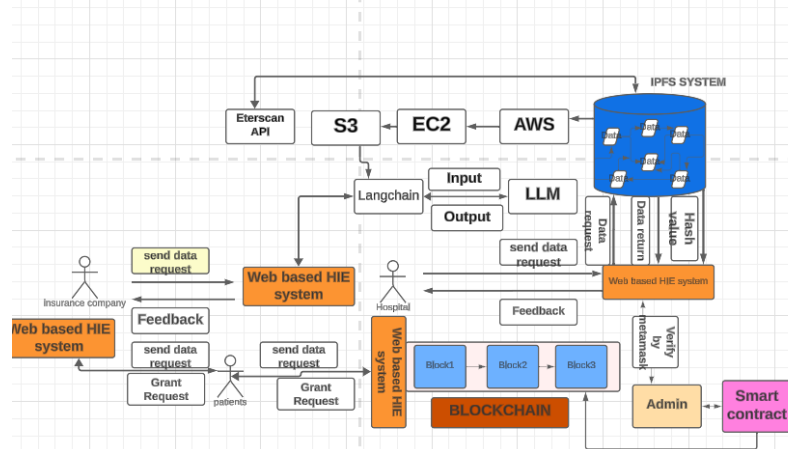

Figure 4. Data Flow for Hospital

5. ARCHITECTURE

This discourse examines the myriad advantages of integrating artificial intelligence and machine learning (AI/ML) into healthcare information exchange platforms, followed by a detailed exploration of their implementation alongside blockchain technology. Initially, the conversation underscores the pivotal role of AI/ML in augmenting governmental decision-making processes in healthcare planning[24]. By harnessing demographic data, including gender, age, and regional distribution, AI/ML enables comprehensive analysis, empowering policymakers to devise well-informed strategies for future healthcare initiatives. Furthermore, the integration of AI/ML enhances interoperability by facilitating seamless data exchange among insurance organizations[25]. Through automated data validation mechanisms, insurers can expedite the verification of patient data, thereby streamlining administrative procedures. Moreover, AI/ML-driven analysis of healthcare data, encompassing disease prevalence and mortality rates, provides invaluable insights into priority areas for healthcare intervention. By discerning patterns and trends, healthcare stakeholders can allocate resources judiciously, ultimately improving public health outcomes[26]. The comprehensive integration of AI/ML within Healthcare information exchange frameworks promises significant advancements in both administrative efficiency and patient care delivery. At the outset, a user-friendly web interface serves as the primary gateway for user interaction within the decentralized application (DApp) ecosystem. This interface is thoughtfully crafted using frontend technologies that align seamlessly with the architecture’s requirements, ensuring intuitive user experiences[27]. Facilitating direct engagement, this interface seamlessly integrates with the broader DApp ecosystem. A comprehensive analysis of the DApp ecosystem reveals two pivotal components: smart contracts and the InterPlanetary File System (IPFS) as shown in (Fig. 1). Smart contracts serve as the backbone, orchestrating backend functionalities such as user validation, access management, and report generation. These contracts leverage blockchain technology to enforce transparent and secure transactional processes[28], [29].

Concurrently, IPFS, hosted on AWS Cloud’s EC2 instance, emerges as a cornerstone of data management within the ecosystem. Integrated with S3 buckets for efficient data storage, IPFS plays a pivotal role in housing essential patient reports and other critical data in JSON format. This architecture ensures robust data integrity and accessibility, fostering seamless interaction with the blockchain. Transactions within the ecosystem are meticulously recorded within blocks of the blockchain, preserving a comprehensive ledger of activities. This immutable ledger not only ensures data integrity but also fosters trust and transparency among participants. Additionally, we have utilized the OpenAI API within our architecture and implementation. This integration facilitates natural language processing capabilities, enabling users to interact with the system in their native languages and receive real-time insights and assistance, thereby en-

hancing overall user experience and system efficiency the whole scenario can be visualize by figure5.

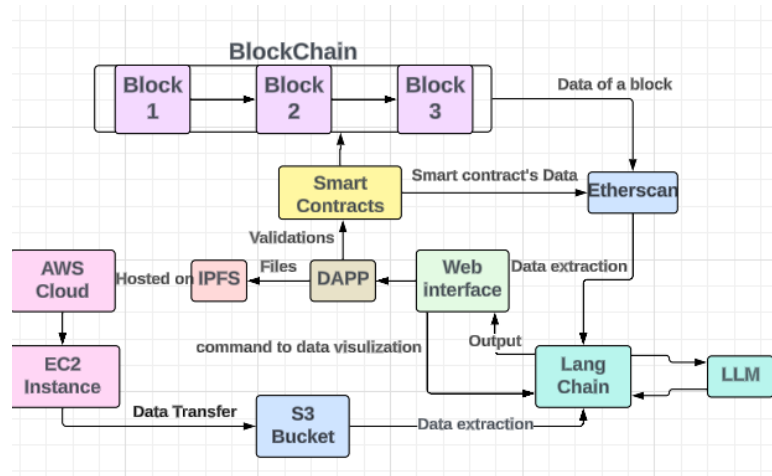

Figure 5. Architecture

In order to effectively leverage AIML algorithms within our system, it is imperative to access and retrieve data from key sources such as blockchain blocks, smart contracts, and S3 buckets. Following comprehensive study and research, we have identified the EtherScan API as a robust solution capable of facilitating data retrieval from blockchain transactions and smart contracts, delivering transactional data in JSON format .As an illustrative example, consider the straightforward process of retrieving the Ether balance for a single address using the EtherScan API as mention in algorithm1

Algorithm1: Load Document from S3

```

Require:aws_access_key_id,
aws_secret_access_key, bucket_name, file_name
Ensure the document is loaded if successful
Create S3 FileLoader instance with provided credentials
and file details.
Try:
from langchain.loaders import EtherscanLoader
loader = EtherscanLoader(
account_address = "xxxxxx",
page = 2,
offset = 20,
start_block = 10000,
end_block = 8888888888,
sort = "asc",) loader.load()
Except Exception as e:
Error, "Failed to load document: ", e

```

By utilising the EtherScan API in conjunction with these parameters, our system can seamlessly retrieve pertinent data from blockchain transactions and smart con-

tracts, facilitating efficient integration with AIML algorithms for further analysis and processing[29]. Following extensive study and rigorous research, it has been determined that LANG Chain presents an optimal solution for accessing and processing data from both S3 buckets and EtherScan, aligning seamlessly with the requirements of our project. Leveraging the LANG Chain API, data retrieval and processing can be efficiently orchestrated to cater to the demands of our system, particularly in responding to queries generated by the Language Learning Model (LLM). For retrieving Ethereum account balances via the EtherScan API, the following code snippet exemplifies the utilization of LANG Chain[30].

This snippet effectively demonstrates the configuration and invocation of the EtherscanLoader, facilitating the extraction of account balance data from EtherScan. The resultant data can then be seamlessly integrated into our system for further processing and analysis. Similarly, for accessing data stored within AWS S3 buckets, LANG Chain provides a streamlined solution, as illustrated below in algorithm5:

Algorithm2: Load Document from etherscan

```
Require: aws_access_key_id,
aws_secret_access_key, bucket_name, file_name
Ensure Document loaded if successful
Create S3FileLoader instance with provided credentials
and file details.
Try:
from langchain.loaders import S3FileLoader
loader = S3FileLoader(
"testing-hwc",
"fake.docx",
awsaccesskeyid="xxxx",
awssecretaccesskey="yyyy")
loader.load()
Except Exception as e:
Error, "Failed to load document: ", e
```

The Blockchain and AI/ML Synergy in Healthcare combines numerous innovative technologies to improve administrative efficiency and patient care delivery. Here are the main components of the system :

A. Decentralized Application (DApp) Ecosystem

1) User-Friendly Web Interface

The web interface is the primary means of user engagement inside the decentralized application (DApp) ecosystem. It is precisely developed with latest frontend technologies to provide an intuitive and smooth user experience. This interface enables users, including consumers, healthcare professionals, and insurance companies, to easily navigate through numerous features. It offers multilingual interactions, allowing users to access and manage their health data, register patients, and submit claims in their

native language. The interface connects directly to the larger DApp ecosystem, allowing for seamless and efficient user involvement.

2) Smart Contracts:

Smart contracts serve as the DApp's backbone, managing the backend capabilities required for the system to work. These include user validation, access management, and report creation. Smart contracts use blockchain technology to automate these procedures, assuring transparency, security, and tamper-proofing. For example, when a patient registers at a hospital, the smart contract confirms their identification and allows them authorized access to their medical information. Similarly, when an insurance business files a claim, the smart contract guarantees that all required data validations are carried out automatically, simplifying administrative operations and eliminating fraud.

3) InterPlanetary File System (IPFS):

The IPFS is a crucial component of the system's data management approach, allowing for decentralized storage of critical patient reports and other data. IPFS is hosted on an AWS Cloud EC2 instance and integrates with S3 buckets to provide efficient and scalable data storage options. IPFS stores data in a distributed fashion, making it highly accessible and robust to faults. Patient data, kept in JSON format, is encrypted and hashed before being posted to the IPFS. This not only maintains data integrity, but also makes the data conveniently accessible and securely shareable among authorized users. The connection with AWS services adds scalability, stability, and cost-effectiveness to the system, allowing it to handle enormous amounts of healthcare data.

Overall, the DApp ecosystem uses cutting-edge technology to provide a safe, efficient, and user-friendly environment for handling healthcare data. A sophisticated online interface, strong smart contracts, and a decentralized storage system via IPFS ensure that the system satisfies the high requirements necessary for current healthcare applications.

B. Blockchain Integration

1) Immutable Ledger:

The construction of an immutable ledger is fundamental to blockchain integration into the HIE system. This ledger stores all transactions throughout the ecosystem in a sequence of linked blocks. Each block includes a cryptographic hash of the preceding block, a timestamp, and transaction data. This structure guarantees that once data is stored, it cannot be changed or removed, resulting in a permanent and tamper-proof record of all operations. The immutable ledger improves data integrity, trust, and transparency among all participants since each transaction is verifiable and traceable. This is especially important in healthcare, where the quality and dependability of patient data are essential.

2) Etherscan API:

To provide real-time and reliable data retrieval, the system employs the Etherscan API. Etherscan is a popular

block explorer that gives users access to precise information on blockchain transactions. By integrating the Etherscan API, the HIE system may retrieve current transaction data straight from the blockchain. This interface allows stakeholders to quickly and effectively validate transactions, monitor the status of smart contract executions, and access other blockchain-related data. The Etherscan API promotes openness and boosts the system's capability to give real-time insights and data verification. Overall, the immutable ledger ensures data integrity; smart contracts automate critical processes; and the Etherscan API enables real-time data retrieval and verification. These components collaborate to increase system security, compliance, and trust, resulting in greater quality and reliability in healthcare services.

C. AI/ML Integration

1) Large Language Models (LLMs):

Large Language Models (LLMs), such as ChatGPT, are important to the AI/ML integration inside the HIE system. These models improve natural language processing (NLP), allowing users to communicate with the system in their local language. LLMs interpret and create human-like writing, allowing patients, healthcare professionals, and insurance companies to communicate with the system easily. This capacity is especially useful for multilingual assistance, since it ensures that customers from various language backgrounds may access and manage their health data, ask questions, and receive detailed replies in real time. The usage of LLMs increases user engagement and accessibility, resulting in a more inclusive and usable experience.

2) Predictive Analytics and Insights:

AI/ML-driven analytics are critical for obtaining useful insights from healthcare data. These algorithms examine massive volumes of data, detecting patterns and trends that may not be immediately evident. Predictive analytics, for example, can aid in the early detection of disease outbreaks by examining patient data from many regions. This enables healthcare practitioners to take preemptive actions, use resources more efficiently, and enhance patient outcomes. AI/ML models may also deliver individualized health suggestions, allowing patients to better manage chronic illnesses and make educated health decisions.

3) Real-Time Business Intelligence:

One of the most notable characteristics of the AI/ML integration is its capacity to give real-time business intelligence. Unlike traditional BI tools, which may cause considerable delays in data processing, the HIE solution uses AI/ML to produce insights immediately. The web-based UI allows hospital managers to request a variety of data and visualizations, including graphs of patient visits, treatment results, and resource consumption. These real-time insights help hospitals make data-driven choices, streamline operations, and improve service delivery. Maintaining a competitive edge and enhancing healthcare services require rapid access to current information.

4) Fraud Detection:

AI/ML models are very useful for detecting and preventing fraud within the HIE system. These algorithms can detect suspect actions in healthcare data by examining trends and anomalies, which could suggest fraudulent claims or data manipulation. For example, an abnormally high number of claims for a specific therapy in a short period of time may prompt an alert. This proactive fraud detection capabilities saves insurance companies from financial losses while also ensuring the integrity of the healthcare system.

D. Data Storage and Management

1) InterPlanetary File System (IPFS):

The InterPlanetary File System (IPFS) plays an important role in the HIE system's data storage strategy. IPFS is a decentralized storage system that distributes data over a network of nodes, resulting in high availability and resilience. IPFS is hosted on AWS Cloud's EC2 instances in the HIE system, which provides a reliable and scalable infrastructure for storing crucial patient reports and other healthcare data. IPFS stores data in JSON format, ensuring that it is well-structured and accessible. The usage of IPFS ensures data integrity since each file is cryptographically hashed and verifiable for authenticity. This decentralization improves data security and accessibility, resulting in a dependable solution for healthcare data administration.

2) AWS EC2 and S3 Integration:

To supplement IPFS's decentralized storage capabilities, the HIE system makes use of AWS services such as EC2 instances and S3 buckets. AWS EC2 provides the computing capacity needed to host IPFS nodes, resulting in efficient data processing and administration. S3 buckets are utilized for scalable and secure data storage, and they seamlessly integrate with IPFS. This hybrid strategy takes use of the benefits of both decentralized and cloud storage, resulting in a highly durable, scalable, and cost-effective solution. The connection with AWS services means that patient data is not only safely kept, but also easily retrievable and controllable, hence enhancing the system's overall efficiency and dependability.

3) Scalability and Flexibility:

One of the primary benefits of utilizing IPFS with AWS for data storage is their scalability and flexibility. The system can simply scale up or down in response to the volume of data and number of users. This flexibility is critical in a hospital context where data quantities might fluctuate dramatically. AWS services, in particular, provide on-demand scalability, allowing the system to deal with huge surges in data flow effectively. This guarantees that the system is responsive and efficient regardless of load.

4) Automated Data Backup and Recovery:

The system includes automatic data backup and recovery methods to protect against data loss. Regular backups of patient data and other vital information are performed, with copies saved in several places throughout the IPFS and



AWS infrastructures. This redundancy assures that in the case of a system failure or data corruption, the data may be recovered swiftly and without loss. The automatic nature of these backups reduces the possibility of human mistake and guarantees that the system recovers quickly from any disturbances.

In summary, the system's data storage and management approach takes use of IPFS's decentralized features, AWS's scalability and dependability, and comprehensive security mechanisms to ensure efficient, safe, and compliant data handling. This holistic strategy guarantees that healthcare data is successfully handled, allowing all stakeholders to have reliable and real-time access while also supporting the overarching aim of improving healthcare delivery and administration.

6. RESULTS

After meticulous research and analysis, the findings of our research paper elucidate the integral role played by the web interface as a primary communication conduit between end-users and the system, facilitating diverse functions seamlessly. This interface serves as a gateway for users to interact with various system functionalities, validated through smart contracts, and stored across disparate locations. Transactions initiated by users are systematically recorded within blocks on the blockchain, ensuring a transparent and immutable ledger of activities. Conversely, critical data such as reports are securely stored within designated S3 buckets, optimizing accessibility and management.

Furthermore, the integration of a chatbot within the web interface enhances user interaction and accessibility. Users can seamlessly engage with the chatbot, issuing commands or queries that are subsequently processed through the LangChain platform. LangChain orchestrates the retrieval of pertinent data from S3 buckets via boto3 and blockchain blocks via the EtherScan API, leveraging advanced protocols for data access and retrieval. Upon receiving user commands, LangChain seamlessly interfaces with the Language Learning Model (LLM) to generate nuanced queries based on user input. These queries are meticulously processed and analyzed by LangChain, culminating in the presentation of refined results to end-users via the web interface.

The flexibility to integrate and use a variety of chat model providers is a fundamental addition of our unified chat model execution framework. To maximise performance, our framework seeks to use native provider capabilities where possible for important tasks such as synchronous invocation, asynchronous execution, streaming output, and asynchronous streaming. The table in Table I highlights the state of native support for our existing chat model integrations. Each row represents a provider integration, while the columns denote support for invoke, async invoke,

TABLE I. Comparison of different LLM

LLM Model	Invoke	Async Invoke	Stream	Async stream
Azure chat OpenAI	YES	YES	YES	YES
Chat GooglePalm	YES	YES	NO	NO
Chat Hugging Face	YES	YES	NO	NO
ChatDataBricks	YES	NO	NO	NO
ChatMiflow	YES	NO	NO	NO
chat OpenAI	YES	YES	YES	YES

streaming, and async streaming activities, respectively. As demonstrated, provider integrations such as Azure Chat OpenAI, and ChatOpenAI provide full native support for all included operations. Other integrations, such as ChatDataBricks and ChatHuggingFace, lack native async invoke and streaming functionality. With this consolidated support summary, our platform can dynamically select the best execution plan for each connected provider. For providers with incomplete native support, our framework may selectively use native implementations while relying on default capabilities for unsupported operations. By maintaining this support matrix, we ensure that our chat model apps can take advantage of cutting-edge provider capabilities while being deployable in an ever-changing ecosystem of services.

7. DISCUSSION

Strong insights can be gained from comparing Snowpark and Pandas AI's data analysis performances. As a result of outperforming Pandas AI in crucial areas, Snowpark comes out on top. Better data processing performance, seamless scalability with growing dataset sizes, reduced infrastructure requirements, and affordability are just a few of its benefits. Snowpark's ability to execute non-SQL code natively within Snowflake is one of its main advantages. This greatly improves performance, especially when transforming large datasets. Benchmarking studies validate Snowpark's strength; in 7 out of 8 use cases, it performed better than Spark, demonstrating its versatility in engineering tasks and dataset sizes. Furthermore, because of its lazy evaluation methodology, Snowpark's operations make use of the computing power of the Snowflake data platform, continuing to operate efficiently even with larger datasets. On the other hand, despite providing generative AI features that are integrated into Pandas dataframes, Pandas AI performs poorly, particularly when working with large datasets. While Pandas AI can answer questions in natural language and can also generate Python code to do so, Snowpark's native integration with Snowflake outperforms Pandas AI, especially when large datasets are being analyzed. Snowpark is therefore a better option than Pandas AI for enterprises looking for the best results in data analysis tasks, particularly when dealing with large datasets, as it offers more efficiency and scalability. The empirical investigation conducted in this study provides a comparative analysis of response times between two prominent data processing frameworks: Pandas AI and Snowpark.

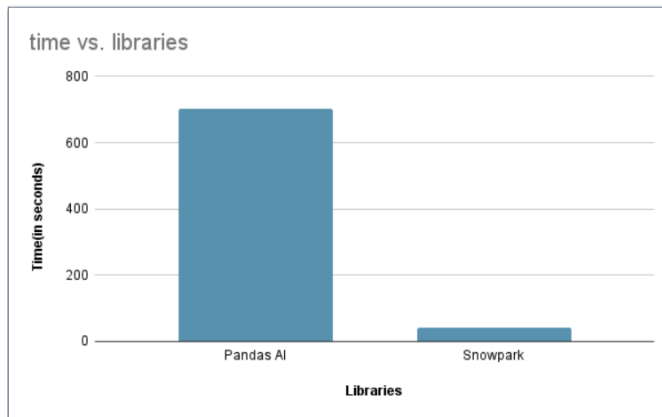

Figure 6.
SnowPark vs Pandas AI

The dataset utilized for this analysis comprised 162,000 rows and 1,422 columns, reflecting real-world scenarios of significant data complexity and magnitude (Fig. 2). Evaluation of the performance metrics revealed that Pandas AI exhibited notably expedited processing time, completing the task in 702 seconds, whereas Snowpark required 421 seconds for the same task. These differences underscore the distinct computational efficiencies inherent within each framework, offering valuable insights into their respective strengths and limitations. Pandas AI's swift response time indicates its adeptness in handling large-scale datasets with intricate structures, making it favorable for scenarios requiring rapid data processing and analysis. Conversely, Snowpark's comparatively long processing duration suggests potential constraints in managing datasets of similar size and complexity. These findings have pragmatic implications for diverse domains reliant on data analytics, including scientific research, business intelligence, and machine learning applications. By elucidating the computational disparities between Pandas AI and Snowpark, stakeholders can make informed decisions regarding framework selection, optimizing resource allocation, and enhancing overall efficiency. The observed performance differentials highlight the evolving landscape of data processing technologies, with advanced AI-driven tools like Pandas AI increasingly favored for their ability to expedite complex computations and streamline analytical workflows. This underscores the need for continual innovation and adaptation within the realm of data science, as organizations seek cutting-edge methodologies for gaining actionable insights from vast data troves. Furthermore, the implications extend beyond academic research, resonating with industry stakeholders navigating the complexities of data-driven decision-making. By embracing technologies offering enhanced computational efficiency, organizations can gain a competitive edge, leveraging data analytics as a strategic asset for driving innovation and growth. The juxtaposition of Pandas AI and Snowpark underscores the broader discourse surrounding the optimization of computational resources and the quest

for scalable, high-performance data processing solutions. As datasets burgeon in size and complexity, the need for agile and efficient frameworks becomes increasingly pronounced, necessitating ongoing advancements in algorithmic design and computational infrastructure.

8. CONCLUSION

6. Conclusion : In conducting this comprehensive study, we have meticulously examined each fundamental technology integral to the system architecture, including Smart Contracts, IPFS, AWS, LangChain, Etherscan, LLM, and others. Through exhaustive analysis and research, we are pleased to announce the successful development of a robust and stable system poised to contribute significantly to the betterment of society. Our endeavor has been guided by a steadfast commitment to leveraging cutting-edge technologies to address critical societal challenges, particularly in the realm of healthcare information exchange. By harnessing the capabilities of Smart Contracts, IPFS, and AWS, we have established a secure and efficient infrastructure capable of facilitating seamless data exchange and interaction within the healthcare ecosystem. Furthermore, the integration of advanced technologies such as LangChain, Etherscan, and LLM has enabled sophisticated data retrieval, processing, and analysis, empowering users with actionable insights and decision-making support. This amalgamation of technologies represents a pivotal step towards realizing the transformative potential of digital innovation in healthcare. However, it is imperative to acknowledge that no system is without limitations. While we have strived to address existing constraints to the best of our abilities, we recognize that there may still be areas warranting further refinement and enhancement. These limitations serve as catalysts for continuous improvement, spurring our commitment to iteratively iterate and evolve the system to meet the evolving needs of society. Moving forward, we remain dedicated to advancing our system, leveraging emerging technologies, and collaborating with stakeholders to overcome challenges and unlock new opportunities for societal benefit. Through ongoing research, innovation, and collaboration, we are confident that our efforts will contribute to the realization of a more efficient, accessible, and equitable healthcare ecosystem for all.

9. FUTURE WORK

In our continued efforts to improve the synergy between Blockchain and AI/ML in healthcare, various new options for future development arise. To begin, addressing scalability improvements is critical to accommodating the increasing amounts of data and users while assuring widespread acceptance throughout the healthcare business. Simultaneously, the creation of strong regulatory frameworks is critical, defining legal and ethical bounds while protecting data integrity and privacy.

Furthermore, addressing technological complexity is critical to ensuring system performance and dependability. This means overcoming current constraints to improve user



experience and operational efficiency. Furthermore, digging into real-world applications presents a viable route for adapting the framework to various healthcare contexts and patient populations. Interdisciplinary collaboration emerges as a critical component, needing coordinated efforts among technologists, healthcare practitioners, and policymakers to match development with stakeholder needs.

Furthermore, developing data analysis skills, particularly in the field of AI/ML, has enormous promise. Research efforts might include fine-tuning algorithms for predictive analytics, tailored treatment, and fraud detection, ultimately improving healthcare delivery. Furthermore, improving data visualization approaches with an emphasis on privacy protection is critical for extracting useful insights while maintaining patient anonymity.

Finally, integrating new technologies like the Internet of Things (IoT) with Blockchain and AI/ML has the potential to transform healthcare data management and delivery. By navigating these trajectories, our goal is to develop and evolve the system, leading to a more efficient, accessible, and equitable healthcare environment that aligns with the changing requirements of society.

REFERENCES

- [1] N. Arunkumar and P. Sivaprakasam, "Blockchain technology in data management," *2020 Fourth International Conference on Computing Methodologies and Communication (ICCMC), Erode, India, 2020*, pp. 199-206, vol. 10, pp. 199-206, 2022.
- [2] Y. S. B. et al, "Development of blockchain-based health information exchange platform using hl7 fhir standards: Usability test," in *IEEE Access*, vol. 10, 2022.
- [3] V. M. G. D. A. D. Aman Ramani, Dhairya Chhabra, "Health information exchange using blockchain," *Communication and Intelligent Systems*, vol. 689, 2023.
- [4] M. R. I. N. F. H. ALAA HADDAD, MOHAMED HADI HABAEBI and S. A. Z. ., "Systematic review on ai-blockchain based e-healthcare records management systems," " *Department of Electrical and Computer Engineering, International Islamic University Malaysia (IIUM), Kuala Lumpur 53100.*, 2022.
- [5] N. A. W. B. Bajwa J, Munir U, "Artificial intelligence in healthcare: transforming the practice of medicine," *Future Healthc J.* 2021 Jul;8(2):e188-e194, 2021.
- [6] K. R. Davenport T, *The potential for artificial intelligence in healthcare*, 2019.
- [7] H. C. M. K. T.-G. R. A. F. L. J. C. J. D. B. F. A. Borna S, Maniaci MJ, *Artificial Intelligence Models in Health Information Exchange*, 2023.
- [8] A. S. A. N. e. a. Alowais, S.A., *Revolutionizing healthcare: the role of artificial intelligence in clinical practice*, 2023.
- [9] R. . D. J. . A. A. . M. J. Miranda, Filipe Sousa, *Machine Learning Applied to Health Information Exchange*, 2022.
- [10] M. R. I. N. F. H. A. Haddad, M. H. Habaebi and S. A. Zabidi, "Systematic review on ai-blockchain based e-healthcare records management systems," in *IEEE Access*, vol. 10, 2022.
- [11] H. . W. W. . H. H. Liu, Guijiang Xie, "A secure and efficient electronic medical record data sharing scheme based on blockchain and proxy re-encryption," *Journal of Cloud Computing*, 2024.
- [12] S. Huang, Alexander Huang, "Increasing transparency in machine learning through bootstrap simulation and shapely additive explanations," *Journal of Cloud Computing*, 2024.
- [13] N. . A. N. . A.-O. I. . A.-H. M. Alblihed, Nwader Almufadi, "Blockchain and machine learning in the internet of things: a review of smart healthcar," *International Journal of Artificial Intelligence (IJ-AI)*, 2023.
- [14] V. K. S. N. P. A. R. Lekha Athota, "Chatbot for healthcare system using artificial intelligence," 2020.
- [15] P. P. S. A. Nguyen DC, Ding M, "A. blockchain and ai-based solutions to combat coronavirus (covid-19)-like epidemics," *IEEE Access*, 2021.
- [16] S. D. S. K. H. Y.-C. Kumar, R. Arjunaditya, "Ai-powered blockchain technology for public health: A contemporary review, open challenges, and future research directions," 2023.
- [17] N. Aldahwan and N. Alsaeed, "Use of artificial intelligent in learning management system (lms): A systematic literature review," *International Journal of Computer Applications*, vol. 175, pp. 16-26, 08 2020.
- [18] Y. . Z. H. . D.-Y. . L. H. . M. S. . W. Y. . D. Q. . S. H. . W. Y. Jiang, Fei Jiang, "Artificial intelligence in healthcare: past, present and future," 2017.
- [19] Eur and P. Mulay, "Blockchain and machine learning based health care management systems," 12 2023.
- [20] H. Jebamikyous, M. Li, Y. S. Kuruba Manjunath, and R. Kashef, "Leveraging machine learning and blockchain in e-commerce and beyond: benefits, models, and application," *Discover Artificial Intelligence*, 2023.
- [21] S. Khan, T. Siddiqui, B. Albahlal, S. Alajlan, and M. Azrour, "Blockchain technologies in healthcare system for real time applications using iot and deep learning techniques," 2023.
- [22] A. J. D. P. Isravel, K. M. Sagayam, B. Bhushan, Y. Sei, and J. Eunice, "Blockchain for healthcare systems: Architecture, security challenges, trends and future directions," *Journal of Network and Computer Applications*, 2023.
- [23] H. K. Bharadwaj, A. Agarwal, V. Chamola, N. R. Lakkaniga, V. Hassija, M. Guizani, and B. Sikdar, "A review on the role of machine learning in enabling iot based healthcare applications," *IEEE Access*, vol. 9, pp. 38 859-38 890, 2021.
- [24] K. S. O. A. Alzubi, J. A. Alzubi and D. Gupta, "Blockchain and artificial intelligence enabled privacy- preserving medical data transmission in internet of things," *2019 International Conference on Automation, Computational and Technology Management (ICACTM)*, vol. 12, 2021.
- [25] S. K. S. N. K. S. H. T. R. Gadekallu, M. M. K. and S. Bhattacharya, "Blockchain-based attack detection on machine learning algorithms

for iot-based e-health applications,” *IEEE Internet of Things Magazine*, vol. 4, 2021.

- [26] S. G. S. A. M. A. H. K. F. M. S. Razzaq, A.; Mohsan, “Blockchain-enabled decentralized secure big data of remote sensing,” 2022.
- [27] S. K. Y. P. R. B. Lade, S. Kale and S. Jain, “Health information exchange using blockchain,” *International Conference on Integrated Intelligence and Communication Systems (ICIICS)*, pp. 1–20, 2023.
- [28] V. Puri, I. Priyadarshini, R. Kumar, and C. Van Le, “Smart contract based policies for the internet of things,” *Cluster Computing*, pp. 1–20, 2021.
- [29] V. A. Shukla, V.K, “Enhancing lms experience through aiml base and retrieval base chatbot using r language,” *2019 International Conference on Automation, Computational and Technology Management (ICACTM)*, 2019.
- [30] B. K. K. Oh, D. Lee and H. Choi, “A chatbot for psychiatric counseling in mental healthcare service based on emotional dialogue analysis and sentence generation,” *18th IEEE International Conference on Mobile Data Management (MDM)*, pp. 371–375, 2021.



Sachin Kumar I am a final year undergraduate B.Tech Computer science student have expertise in Data Science, Data engineering and AI/ML.I has refined my talents over my academic career by taking on a variety of development internships in various organizations.A. research he just prepared on the usage of blockchain in the AI/ML with block chain demonstrates my understanding of cutting-edge technology and its practical

applications These experiences not only provided valuable information, but also fueled his determination to thrive in the software engineering field.



Dr. Shitalkumar Jain is a highly skilled professional With around 20 years of teaching experience. His areas of expertise are software engineering and computer networks, and he is presently a professor at the MIT Academy of Engineering. Dr. Jain He has completed Ph D. in Computer Engineering in the area of Ad Hoc Networks from NMIMS University, Mumbai. He is actively involved in research and development activities in the college and has received the funds of Rs. 3,40,000/- from BCUD, SPPU, Pune. forefront area of research : Networking, Network Security, Blockchain, Wireless Ad Hoc and Sensor Network. His competence and contributions to the academic community are demonstrated by the numerous articles he has written in these subjects at reputable conferences and journals.



Rohit Lade is a final-year student at MIT Academy of Engineering, where he is pursuing a Bachelor of Technology in Computer Engineering. He has started contributing to the fields of cybersecurity, cloud computing, and Java technologies, which he finds intriguing. Throughout his academic career, he honed his skills by doing a range of development internships with various firms.

These experiences have taught him significant lessons and spurred his drive to thrive in the software engineering field.